



Schweizerische Eidgenossenschaft
Confédération suisse
Confederazione Svizzera
Confederaziun svizra

Swiss Confederation

Federal Department of the Environment, Transport, Energy and
Communications DETEC

Federal Office of Civil Aviation FOCA

Aviation Policy and Strategy
Environmental Affairs

AIRCRAFT PISTON ENGINE EMISSIONS

Appendix 4: Nanoparticle Measurements and Research for Cleaner AVGAS



Picture 1: Nanoparticle measurements of two different aircraft piston engines fuelled with leaded and unleaded aviation gasoline. (Oberpfaffenhofen Airport (EDMO), Germany)

FOCA, CH-3003 Bern

Reference: 0 / 3/33/33-05-003 ECERT

Contact person: Theo Rindlisbacher

Tel. +41 31 325 93 76, Fax +41 31 325 92 12, theo.rindlisbacher@bazi.admin.ch

This document has been released for publication by FOCA, Aviation Policy and Strategy, Director M. Zuckschwerdt, 11.06.2007

Contents

	Page
1. Background, motivation and project partners	3
1.1 Research programme	3
1.2 Research goals	3
2. General results for nanoparticle emissions of an aircraft gasoline engine, running under rich air/fuel conditions (AVGAS 100 LL)	3
2.1 Preparations	3
2.2 SMPS™ system layout and description for particle measurements	4
2.3 Results	6
2.4 Picture documentation of first non-volatile nanoparticle measurements	9
3. Looking for particle emission improvements: First tests with unleaded AVGAS (AVGAS 91/96 UL)	11
3. 1 Introduction and description of AVGAS 91/96 UL	11
3.2 Composition of measured AVGAS 100LL (560 mg Pb / liter)	11
3.3 Used aircraft	12
3.4 Results for HB-EYS	12
3.5 Conclusion for HB-EYS tests	13
3.6 Results for SE-KEI	13
3.7 Air/fuel mixture ratio for HB-EYS and SE-KEI	14
3.8 Discussion	15
3.9 Conclusions for AVGAS 91/96 UL	15
4. Change from SMPS™ to Engine Exhaust Particle Sizer™ (EEPS 3090™) system for aircraft piston engine nanoparticle measurements	15
4.1 Introduction	15
4.2 EEPS™ system description	15
4.3 Application of EEPS™ for aircraft piston engine measurements	16
4.4 EEPS™ results	18
4.5 First conclusions for EEPS™ measurements	19
5. Research for AVGAS 100LL substitution and emission reduction	19
5.1 Test fuels	20
5.2 Test location	20
5.3 Used aircraft	20
5.4 Measurement systems	20
5.5. Power settings	21
5.6 Results	22
5.7 Discussion	31
5.8 First conclusions	32

1. Background, motivation and project partners

The results for most in-flight tests documented in Appendix 2 showed engine operation at extremely rich air/fuel ratios. It is known that fuel rich conditions can form soot nanoparticles even in gasoline engines. Given the fact that standard aviation gasoline is still leaded today, there was even more evidence for possible nanoparticle emissions.

Through the European AERONET network, Swiss FOCA started collaboration with the Institute of Combustion Technology of the German Aerospace Centre (DLR) in Stuttgart (Germany), recognizing their vast experience in nanoparticle measurement techniques and their high reputation in research of aero engine combustion processes. DLR Oberpfaffenhofen (Germany) provided the necessary infrastructure for the aircraft on ground measurements at Oberpfaffenhofen Airport (Germany).

At the same time and through AERONET as well, Swiss FOCA got to know Swedish Hjelmcö™ Company, the only producer of lead free AVGAS worldwide, which is meeting ASTM D910 AVGAS specifications. The company can in 2007 claim more than 26 years of lead free AVGAS flying experience in Sweden.

At a later step, collaboration started with German TSI™. The company provided their fast response engine exhaust particle sizer (EEPS™) for in-field testing.

Research for cleaner, lead free AVGAS was done in Switzerland, at St. Stephan Airport (LSTS) in the Swiss Alps. The airport is a former military airport, privately owned and belongs to the company “pro-spective concepts”, which generously provided their infrastructure.

1.1 Research programme:

Step 1: Nanoparticle measurements of a gasoline piston aircraft engine running under rich air/fuel conditions, using standard leaded AVGAS (AVGAS 100LL)

Step 2: Nanoparticle measurements of gasoline piston aircraft engines running under rich air/fuel conditions, using AVGAS 100LL (leaded) and the Swedish AVGAS 91/96 UL (unleaded).

Step 3: Optimization of AVGAS 91/96 UL for higher knocking margin and lowest possible emissions. Use of three aircraft (three different engines) and ten different fuels.

1.2 Research goals:

- 1) Development and testing of a ground and in-field nanoparticle measurement methodology and measurement system.
- 2) Determination of nanoparticle emissions from aircraft piston engines.
- 3) Investigating possible emission improvements by use of unleaded AVGAS.
- 4) Use of knowledge for support, development and application of nanoparticle measurements also for jet engines. This goal is connected with international activities in ICAO CAEP¹ of Swiss FOCA.

2. General results for nanoparticle emissions of an aircraft gasoline engine, running under rich air/fuel conditions (AVGAS 100 LL)

2.1 Preparations

Step one of the research program started in April 2004. Measurements took place in Oberpfaffenhofen EDMO (Germany). The test aircraft was HB-KEZ whose engine (Lyc IO-360 series) had shown very rich combustion at mixture “full rich” conditions (see Appendix 2, section 4d).

¹ Committee on Aviation Environmental Protection of the International Civil Aviation Organization, defining standards and recommended practices also for environmental aircraft/engine certification.

Gaseous emissions of HB-KEZ were measured with the FOCA “low cost” system as described in Appendix 1. The methodology, which was used for the ground power settings, is described in Appendix 3, section 6.4.

Table 1: Measured CO and CO₂ concentrations of HBKEZ on 13th April 2004 for different standard power settings, as described in Appendix 3, section 6.4. (TO = take-off, CL = climb, CR = cruise (rich), AP = approach, TA = taxi, CR L= cruise lean). Running on very rich air/fuel ratio is represented by extremely high CO concentrations and low CO₂ concentrations. The measurement numbers were assigned for the particle measurements

Meas. Nr.	LTO	CO (Vol. %)	CO ₂ (Vol. %)
-	TO	12.506	6.99
6	CL	12.654	6.84
9	CR	12.674	6.82
12,11	AP	13.665	6.23
13,15	TA	10.536	8.06
18	CR L	1.42	13.63

2.2 SMPS™ system layout and description for particle measurements

Non-volatile nanoparticles are extremely small particles in the range of 10 to 500 nanometers (one hundred thousandth of a millimeter). There is growing concern about negative health effects from such particles. They are formed as a result of incomplete combustion. Some of them are potentially toxic and the small size allows them to easily enter the human body deep into the lungs and to penetrate even into nerve cells and the brain. Measurement systems (including sampling processes) need to be sophisticated. General metrics are the size and number distribution (concentration).

The first measurements were performed with a SMPS™ (Scanning Mobility Particle Sizer) System TSI 3080™. Such a system classifies the particles first by their size. The classification is done with electrostatic forces in a so called DMA (Differential Mobility Analyzer). When a certain size class is “filtered”, the number per volume (controlled by sample flow and known dilution) is counted in a CPC (Condensation Particle Counter) (figure 1). The scanning and counting through the size range of 10 to 500 nm usually can take several minutes. This is the measurement time per power mode.

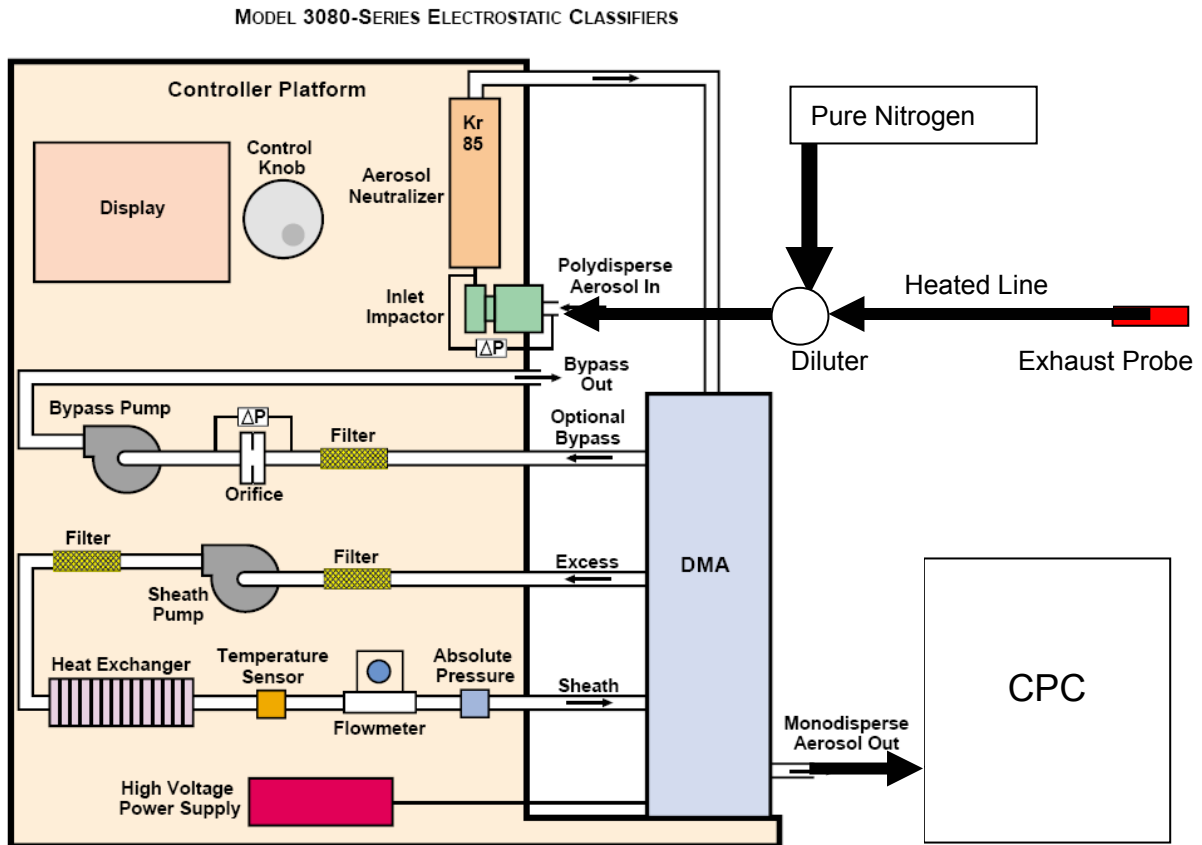

Figure 1: System layout for nanoparticle measurements with an electrostatic classifier and CPC. Explanations are given in the text. [TSI™]

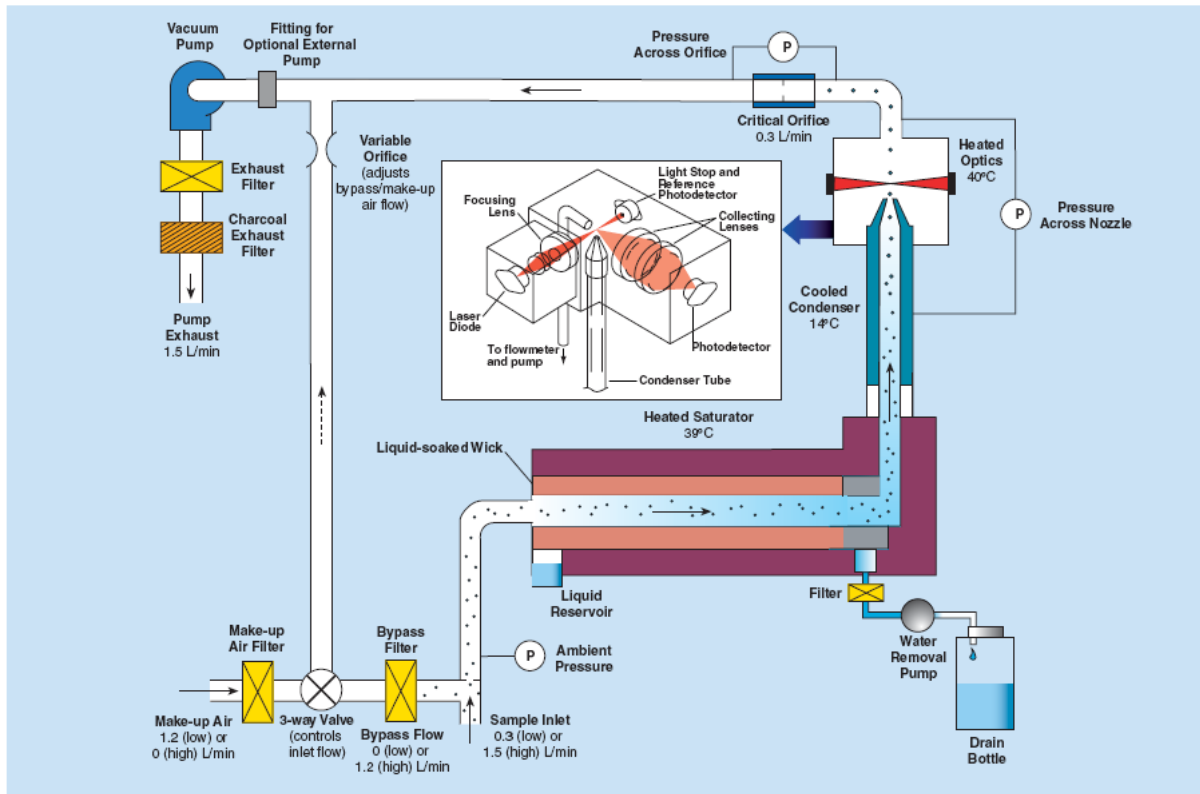

Figure 2: Scheme of a CPC (Condensation Particle Counter) used for counting the number of particles of a certain class of size (Example: TSI™ Model 3775). [TSI™]



Picture 2: Stainless steel exhaust probe and heated sampling line (150°C). Total length 4.5 meters.

For best measurement results, the sampling line has to be as straight and as short as possible. The DLR sampling line measures 4.5 meters only. The material has to be stainless steel, heated to 150°C. Other materials like Teflon™ would absorb fractions of the particles. The exhaust is diluted by a heated Dekati™ diluter 1:10. Dilution air is nitrogen with a minimum quality of 4.5. For calibrating sampling line losses, DLR/Wahl has developed and patented a nanoparticle generator, which produces particles at defined and adjustable sizes. Calibration of sampling lines for size dependent losses has been carried out. However, absent such calibration in the international measurement community for the time being, it has not been applied to the measurements, for reasons of comparison with other engine types and engine technology.

2.3 Results

Figure 3 shows a typical example of a particle size distribution from an aircraft gasoline piston engine, running on AVGAS 100LL (leaded fuel) under rich air/fuel ratio. For the different power modes,

- the **mean diameter** varied between **49 and 108 nm** and
- the total **concentration** between 5.7 to 8.6 times **10 million particles per cubic centimeter**.

With an assumed specific density for soot of 1.2,

- the estimated **mass concentration** was around **10 000 micro grams per cubic meter**. (see picture 3)

The result for this **gasoline** engine is very comparable to the number-size distribution of a typical **diesel** passenger car engine without particle filter (see figure 4)!

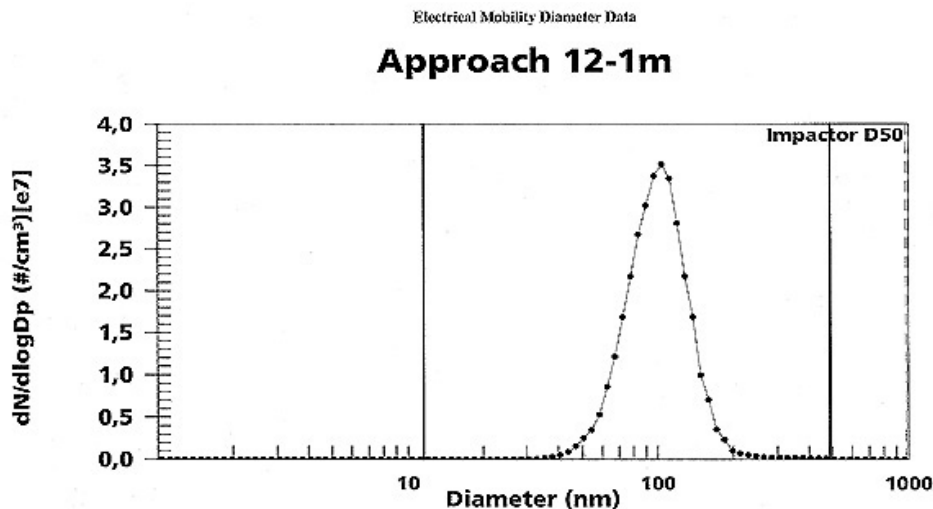

Figure 3: Number-size distribution of HB-KEZ engine at approach mode. The mean particle diameter is around 100 nm and the total concentration is in the order of 10 million particles per cubic centimeter.

File: CD114.000 Sample number: 1 Scan number: 1 Tue 21 Aug 2007
14:42:34

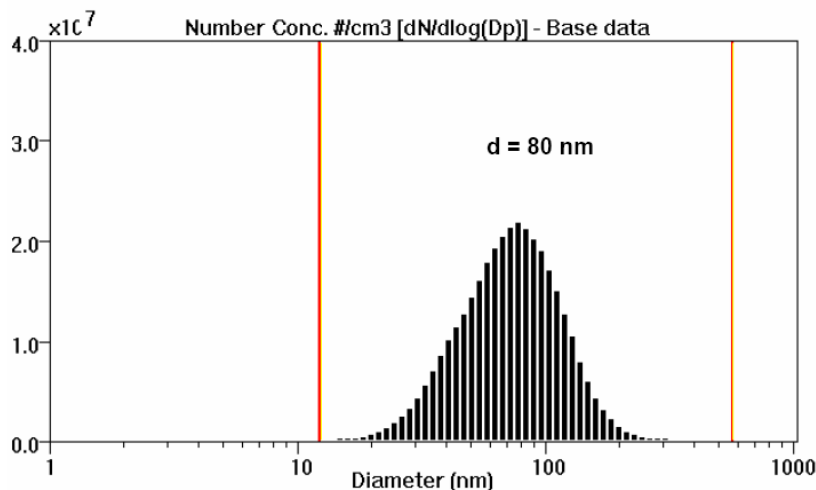

Figure 4: Number-size distribution of a typical diesel passenger car (CDI) at 2000 RPM (increased idle) for comparison to the HB-KEZ measurements [C. Wahl/M. Kapernaum/DLR 2004!]

At lower power settings, exhaust has been pumped through sample cartridges at controlled flow rate for later HC speciation with HPLC (High Performance Liquid Chromatography). Pumping time usually was 2 minutes. Figure 5 shows the result for the measurement of Carbonyls at approach mode. The speciation was obtained by analysis of the filter material with a gas chromatograph and mass spectrometer. Surprising was the amount of produced formaldehyd (see figure 6).

HPLC-chromatogram carbonylcompounds sample No. 12

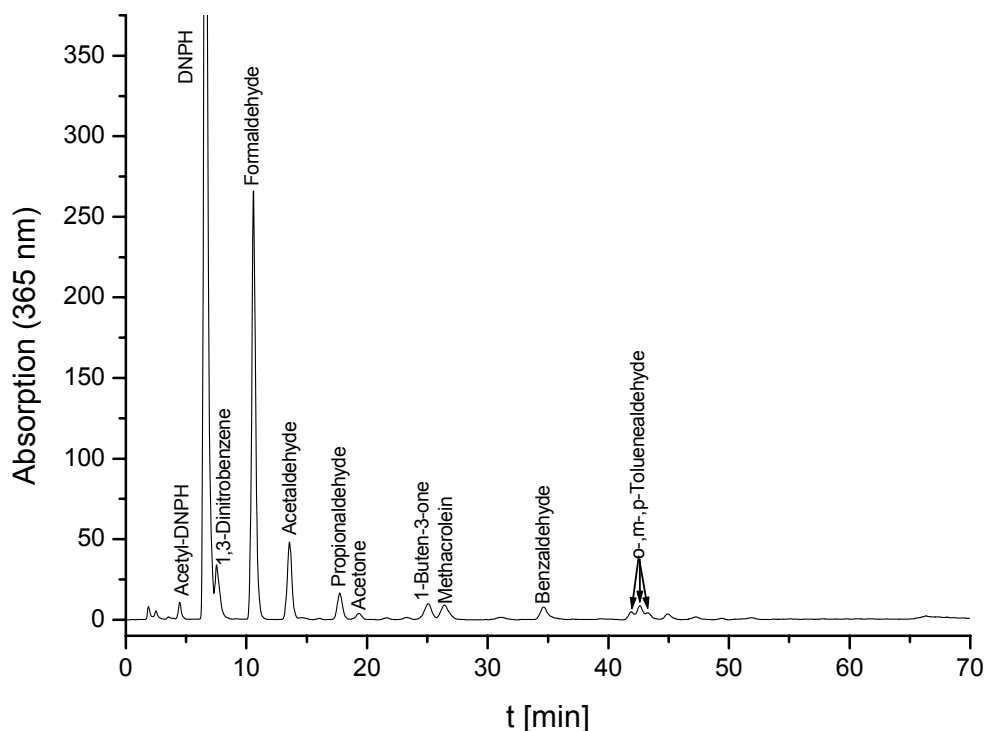

Figure 5: Detected carbonyls at approach mode. [C. Wahl/M. Kapernaum/DLR 2004]

	Nr. 6		Nr. 12		Nr. 15		Blindwert
	ppb	mg/kg Fuel	ppb	mg/kg Fuel	ppb	mg/kg Fuel	ppb
Formaldehyd	8337,48	92,49	6346,26	68,98	5867,59	68,24	21,29
Acetaldehyd	999,68	16,27	744,04	11,87	848,79	14,48	7,08
Propanal	639,90	13,73	532,20	11,19	707,13	15,91	0
Aceton	98,92	2,12	95,11	2,00	95,59	2,15	10,26
1-Buten-3-on	831,43	21,53	781,08	19,82	862,45	23,41	0
Methacrolein	213,53	5,53	184,10	4,67	198,74	5,40	0
Butanal	87,75	2,34	0	0	0	0	0
Benzaldehyd	347,12	13,61	297,51	11,43	333,92	13,72	0
o-Toluolaldehyd	162,52	7,21	141,79	6,17	136,54	6,35	0
m-Toluolaldehyd	294,13	13,06	260,23	11,32	281,54	13,10	0
p-Toluolaldehyd	79,40	3,52	80,54	3,50	71,96	3,75	0
Summe	12091,88	191,42	9462,85	150,95	9404,27	166,51	38,63

Figure 6: Summary of carbonyl measurements at climb mode (nr. 6), approach mode (nr. 12) and taxi mode (nr. 15). [C. Wahl/M. Kapernaum/DLR 2004]

Formaldehyde is dominating carbonyl emissions of the tested engine, running on AVGAS 100LL at standard very rich air/fuel mixture.

2.4 Picture documentation of first non-volatile nanoparticle measurements



Picture 4: "In-field laboratory" at Oberpfaffenhofen Airport (EDMO) and candidate aircraft HB-KEZ.



Picture 5: SMPS (on the left) with DMA (the vertical tube). The CPC is installed behind the Laptop.



Picture 6: This picture was taken during approach mode measurement. The SMPS is placed in the back compartment of the car (as shown in picture 5) and is brought as nearly as possible to the aircraft, for shortest possible sampling line and lowest possible particle losses.



Picture 7: Measurement team which performed – to our knowledge – the first successful measurement of non-volatile nanoparticles of an aircraft gasoline piston engine. From left to right: Manfred Kaper-naum, Claus Wahl (both DLR Stuttgart), Werner Bula, Theo Rindlisbacher (both FOCA)

3. Looking for particle emission improvements: First tests with unleaded AVGAS (AVGAS 91/96 UL)

3.1 Introduction and description of AVGAS 91/96 UL

Through AERONET network, FOCA came into contact with Lars Hjelmsberg from Swedish Hjelmsco™ Oil company, which in 2007 is producing unleaded AVGAS since more than 26 years. Unleaded AVGAS has become a standard fuel in Sweden. Because it meets the AVGAS standard ASTM D910, no Supplemental Type Certificate (STC) for the aircraft is needed to use that fuel. It is important to notice, that the AVGAS specifications do not prescribe any minimum lead content. The only limitation for the use of the Swedish fuel comes from the lower aviation octane rating compared to the leaded AVGAS 100LL. The engine manufacturer Textron Lycoming has included AVGAS 91/96UL, which is Hjelmsco's second generation of unleaded AVGAS, as an approved alternate aviation gasoline for a large number of their engines already in the year 1995. The engines with type numbers are listed in service instruction No. SI 1070. Generally speaking, only highest pressure ratio engines, especially turbocharged gasoline piston engines, can not use AVGAS 91/96 UL in their standard configuration.

Swiss FOCA had AVGAS 91/96 UL analyzed and some interesting properties were found:

- The fuel is composed of a surprisingly low number of components compared to 100LL
- The components are extremely pure
- There is no benzene, no sulphur
- There is no dye (the fuel is clear like water)
- The fuel meets AVGAS specification ASTM D910

A hypothesis was set up, that the use of AVGAS 91/96 UL instead of AVGAS 100LL could significantly reduce particle emissions, both in terms of mass and in terms of number.

To test the hypothesis, two aircraft whose engines are in the manufacturers list for running on unleaded AVGAS 91/96 UL, were selected. Both engines were run on AVGAS 100LL (max lead content 560 mg / liter) and on unleaded 91/96 UL. DLR used the SMPS (as described in section 2), Scanning Electron Microscopy (SEM), Energy Dispersive X-ray spectroscopy (EDX) for particle properties investigation. Additionally, DLR performed aldehyde tests (DNPH method). Engine power for selected power modes (Take-off, Climb, Cruise, Approach and Taxi) was adjusted according to the FOCA methodology for static on-ground tests, as described in Appendix 3, sections 6.2 and 6.3.

3.2 Composition of measured AVGAS 100LL (max 560 mg Pb / liter)

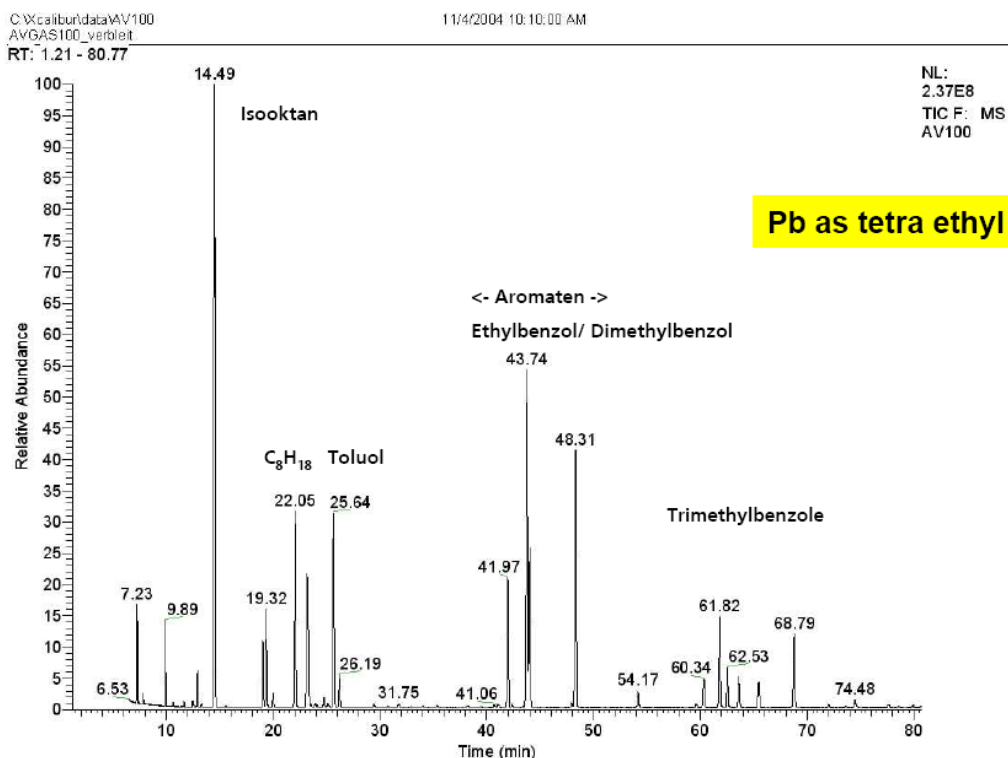

Figure 7: Composition of measured AVGAS 100LL [C. Wahl/M. Kapernaum/DLR]

3.3 Used aircraft

HB-EYS Type: Robin DR400
 Owner: Swiss Confederation
 Engine: Lyc O-360 series, 180 HP
 Carburetor

SE-KEI Type: Piper PA28 Warrior II
 Owner: Hjelmsco Oil, Sweden
 Engine: Lyc O-320 series, 160 HP
 Carburetor

3.4 Results for HB-EYS

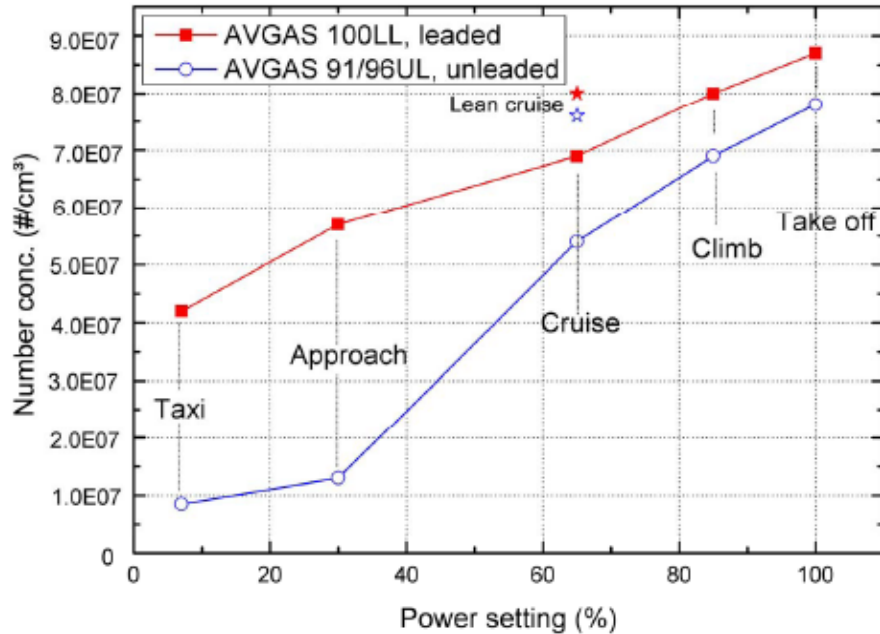

Figure 8: Non-volatile particle number concentrations for AVGAS 100LL and 91/96 UL in function of propeller power (HB-EYS). [C. Wahl/M. Kapernaum/DLR]

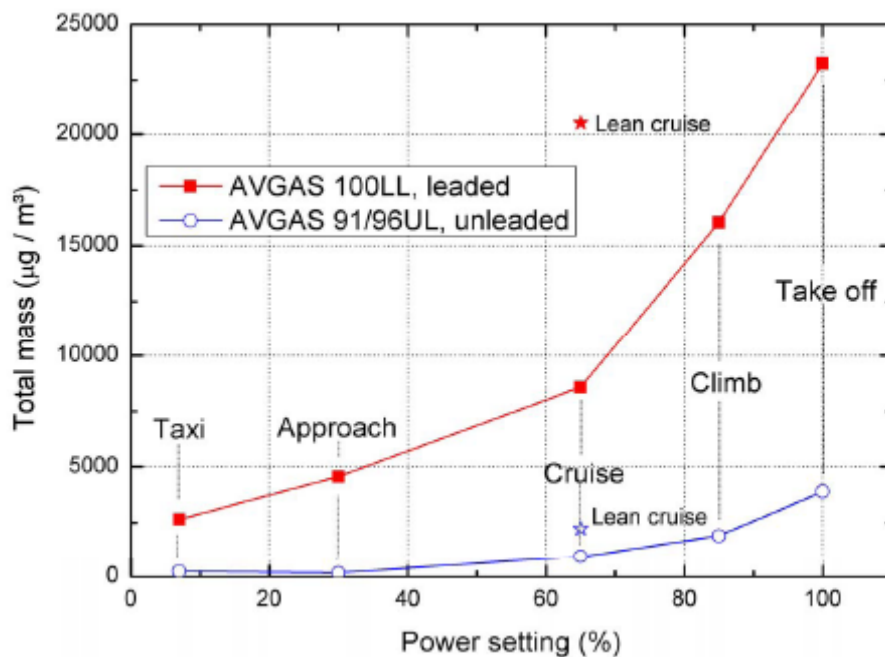

Figure 9: Total non-volatile particle mass concentration for AVGAS 100LL and 91/96 UL in function of propeller power (HB-EYS) [C. Wahl/M. Kapernaum/DLR]

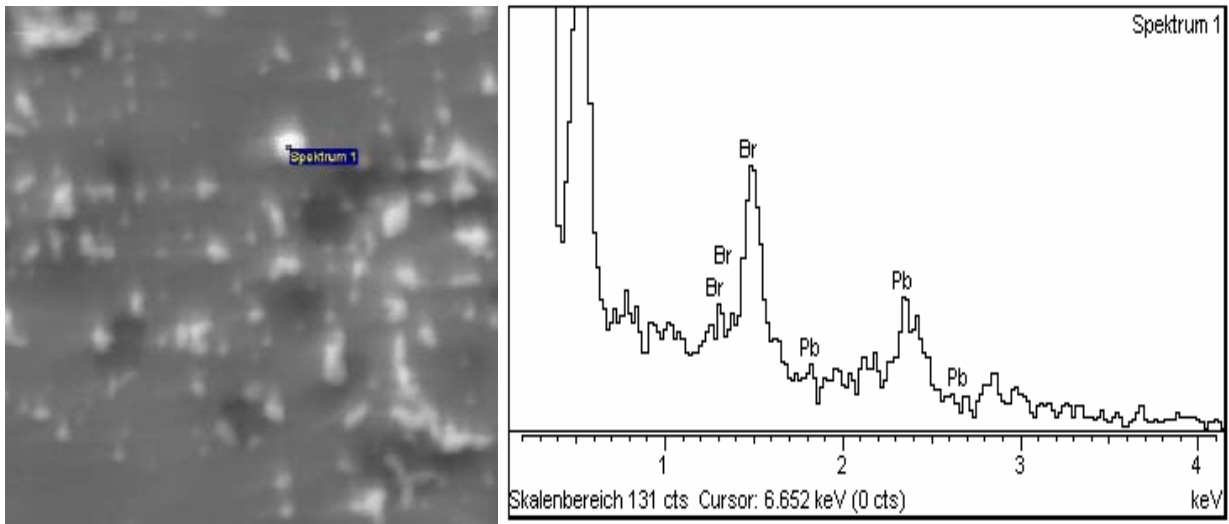

Figure 10: Using EDX, both, Lead (Pb) and Bromide (Br) containing particles from AVGAS 100LL exhaust could be identified (HB-EYS). In the picture on the left, the location of the spectrum 1 is indicated with a tag. [C Wahl/DLR].

3.5 Conclusion for HB-EYS tests

- AVGAS 100LL forms soot and lead bromide particles.
- Besides lead additive, also bromides must be contained in AVGAS 100LL. (Bromides are actually used as scavenger, which should help to reduce lead deposits in the engine...)
- Running HB-EYS on AVGAS 91/96 UL (lead free) still gives some lead bromides, which can be explained by the fact that the engine has been running on leaded fuel for its whole life and there are huge lead deposits e.g in the oil pan of the engine.

The use of AVGAS 91/96 UL in HB-EYS gives a significant reduction in non-volatile particle concentration and mass.

3.6 Results for SE-KEI

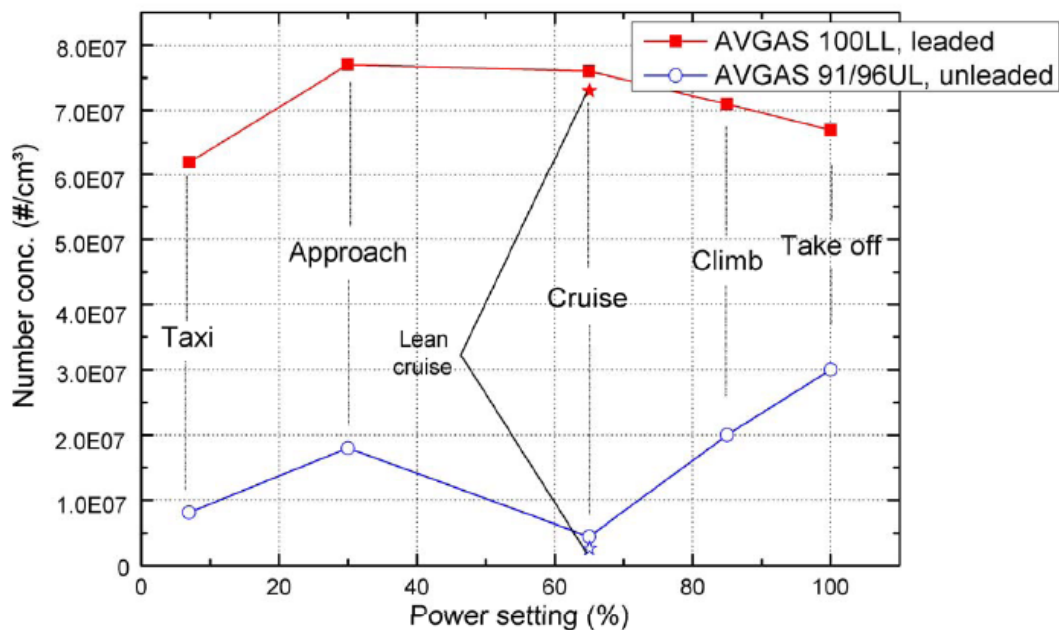

Figure 11: Non-volatile particle number concentrations for AVGAS 100LL and 91/96 UL in function of propeller power (SE-KEI). [C. Wahl/M. Kapernaum/DLR]

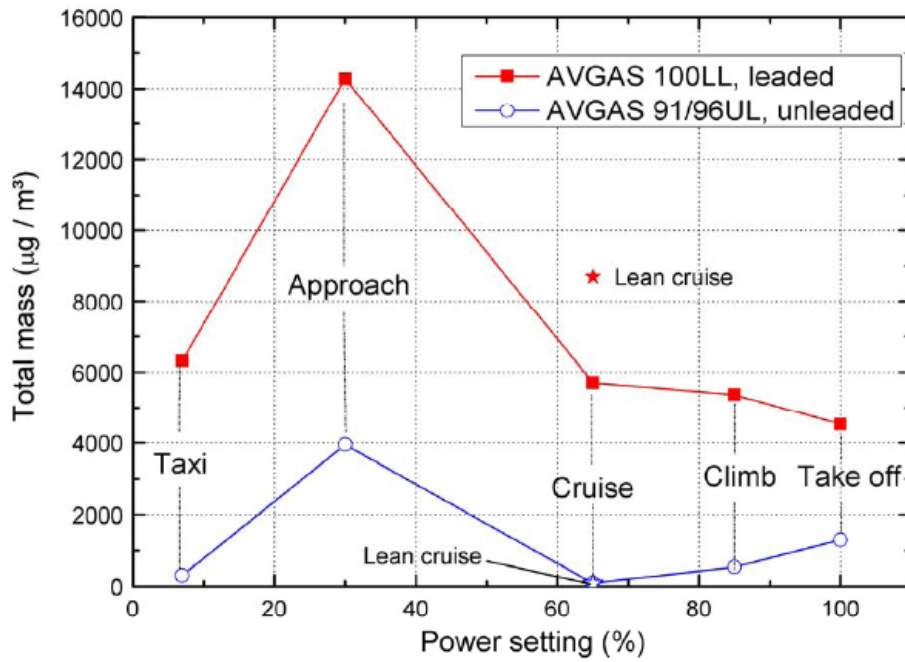

Figure 12: Total non-volatile particle mass concentration for AVGAS 100LL and 91/96 UL in function of propeller power (SE-KEI) [C. Wahl/M. Kapernaum/DLR]

3.7 Air/fuel mixture ratio for HB-EYS and SE-KEI

Combustion quality is greatly influenced by the air/fuel mixture. The air/fuel mixtures at different power settings were recorded, using the FOCA analyzer described in Appendix 1.

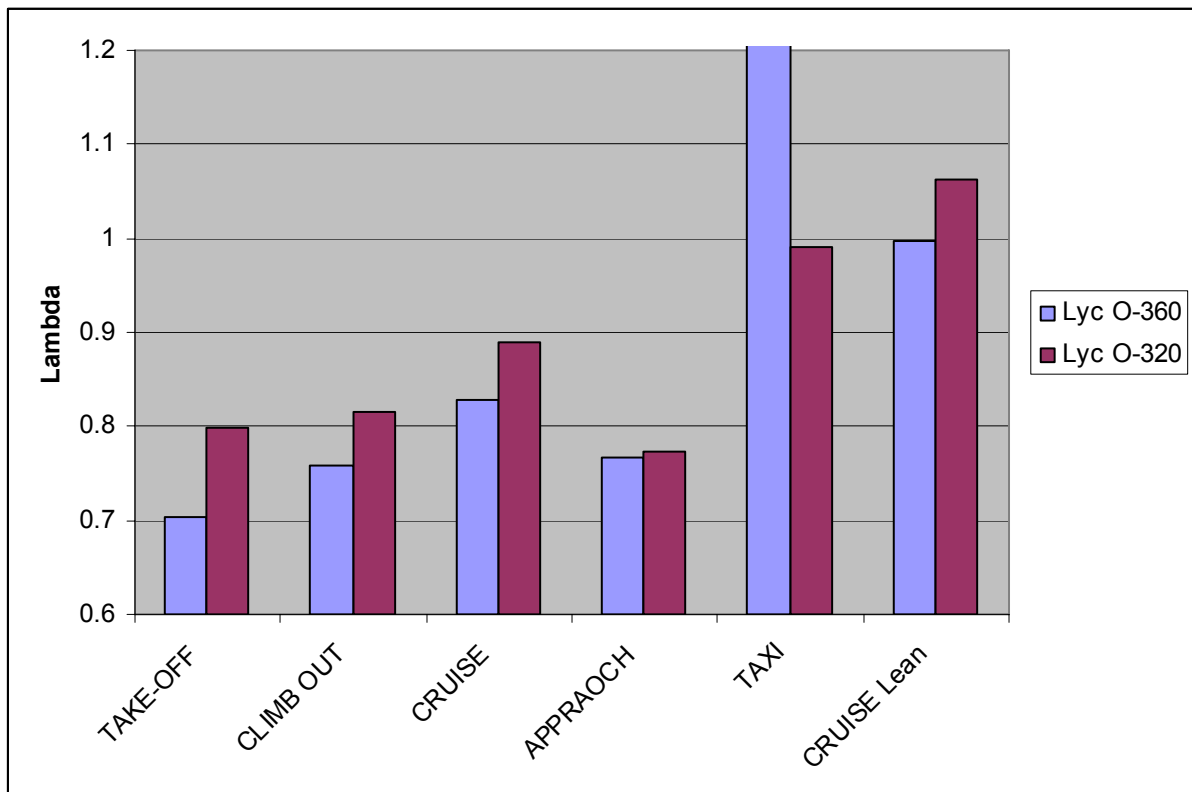

Figure 13: Comparison of air/fuel mixture (Lambda) between the measured Lyc O-360 (HB-EYS) and Lyc O-320 (SE-KEI) for different power modes during the AVGAS 100LL measurements. The engine Lyc O-360 of HB-EYS runs on a significantly richer air/fuel mixture than that of SE-KEI, with the exception of the taxi mode. For explanation of lambda, see Appendix 5.

3.8 Discussion

The carburetor system of SE-KEI is behaving differently from that of HB-EYS. Especially at high power, the engine of SE-KEI is running less rich than that of HB-EYS. Apart from different carburetor systems and tuning, the four blade propeller of SE-KEI might add to that effect, providing the air intake system with slightly increased manifold pressure. As a result of this different behavior, the shapes of the corresponding curves in figures 8 and 11, and in figures 9 and 12 respectively, are very different. However, in both cases, with use of AVGAS 91/96 UL, the mass and number concentrations are significantly reduced.

3.9 Conclusions for AVGAS 91/96 UL

- The use of AVGAS 91/96 UL gives a **significant reduction in non-volatile particle concentration and mass, compared to AVGAS 100LL**
- AVGAS 91/96 UL has **no lead and no bromide emissions**.

- As described in the introduction, the highest pressure ratio piston engines equipped with a RPM invariant ignition system are not allowed to use AVGAS 91/96 UL.
Given the fact, that
- unleaded AVGAS has a significantly superior environmental performance,
- unleaded AVGAS can increase engine operational safety (no spark fouling, no lead deposits, still tight aviation gasoline specs, more than 26 years Swedish experience)
- unleaded AVGAS is needed for state-of-the art engine management and the use of exhaust after treatment systems like catalysts,
research and regulatory initiatives are necessary to further develop and promote AVGAS 91/96 UL as a full substitute for AVGAS 100LL (see section 5).

4. Change from SMPS™ to Engine Exhaust Particle Sizer™ (EEPS 3090™) system for aircraft piston engine nanoparticle measurements

4.1 Introduction

The Engine Exhaust Particle Sizer™ (TSI EEPS 3090™) spectrometer is a fast-response instrument that measures very low particle number concentrations in diluted exhaust. It offers a time resolution of 10 times per second, which makes it well-suited for dynamic and transient tests. It was developed for continuous measurement of entire test cycles. It measures the size distribution and number concentration of engine exhaust particle emissions in the range from 5.6 to 560 nanometers. Compared to the SMPS™, the TSI EEPS 3090™ system

- measures fast response (real time) particle number-size-distributions (+)
- significantly reduces engine running time (+)
- makes particle emissions in transient power settings visible (+)
- shows whether a certain power setting produces stable emissions (+)
- has a reduced size resolution and a reduced overall accuracy (-)

4.2 EEPS™ system description

[Source: TSI™]: The instrument draws a sample of the exhaust flow into the inlet continuously. Particles are positively charged to a predictable level using a corona charger. Charged particles are then introduced to the measurement region near the center of a high-voltage electrode column and transported down the column surrounded by HEPA-filtered sheath air. A positive voltage is applied to the electrode and creates an electric field that repels the positively charged particles outward according to their electrical mobility. (Figure 14)

Charged particles strike the respective electrometers and transfer their charge. A particle with higher electrical mobility strikes an electrometer near the top; whereas, a particle with lower electrical mobility strikes an electrometer lower in the stack. This multiple-detector arrangement using highly sensitive electrometers allows for simultaneous concentration measurements of multiple particle sizes.

The Model 3090 uses a real-time data inversion to deconvolute data. The inversion accounts for variability in particle charge, image charge, multiple voltages on the center rod, and detection time to present a size distribution

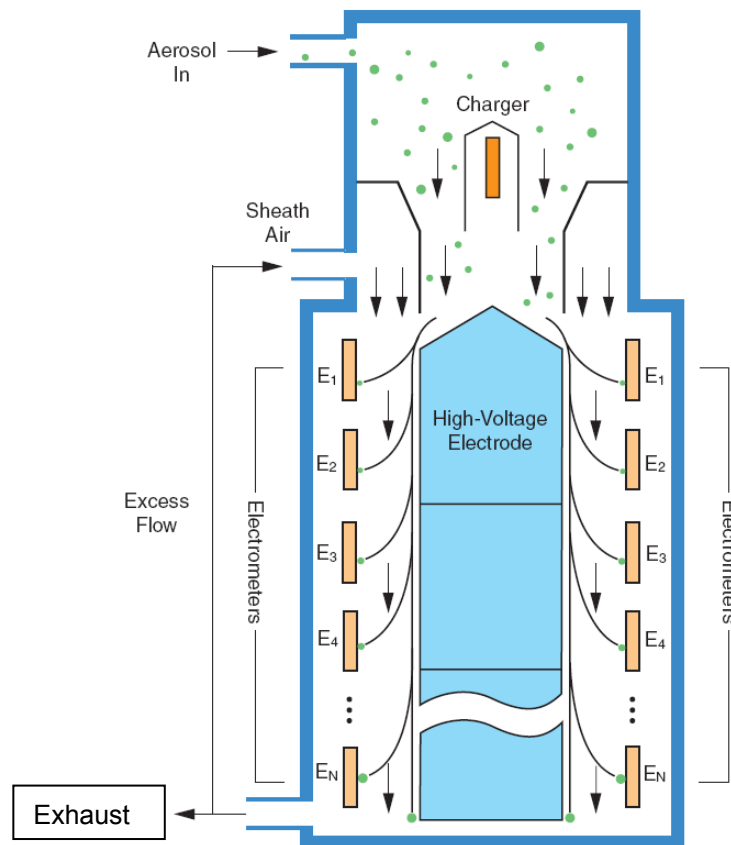

Figure 14: EEPS™ flow schematic [TSI™]

4.3 Application of EEPS™ for aircraft piston engine measurements

Between 29th March and 4th April 2005, one year after the first non-volatile nanoparticle measurements in Oberpfaffenhofen, Germany, the same aircraft (HB-KEZ) with the same engine was measured again, this time with TSI EEPS 3090™. The main goals were:

- Application test for in-field measurement with EEPS™ at low ambient temperatures
- Comparison to SMPS™ measurements
- Reproducibility test

The measurement arrangement and the sampling line were identical to the measurements of April 2004 (see section 2.2) with the exception that the SMPS™ was replaced by the EEPS™ and the dilution ratio adjusted to 1 : 100.

Ambient temperatures were as low as 9°C with a relative humidity of nearly 100%. At those ambient conditions, the EEPS™ was working in-field without any problems. However, measurements for comparison with SMPS™ results were made later, at dry ambient conditions.

The methodology, which was used for the ground power settings of the engine, was identical to the procedure of 2004 (as described in Appendix 3, section 6.4). In 2004, the SMPS™ measurements were limited to low power settings, due to the necessary sampling time of two minutes and the limited engine running time, with the aircraft standing on ground.

With EEPS™ it was possible to measure the high power settings as well: The measurement team could visually follow the stabilization of the number-size distribution on the PC screen. Engine running times at high power with the aircraft standing could be reduced to less than half a minute.



Picture 8: EEPS™ measurements with HB-KEZ at Oberpfaffenhofen (EDMO), Germany, March 2005



Picture 9: EEPS™ installed in the back compartment of a car.



Picture 10: Small ground power unit for In-field supply of electricity.

4.4 EEPS™ results

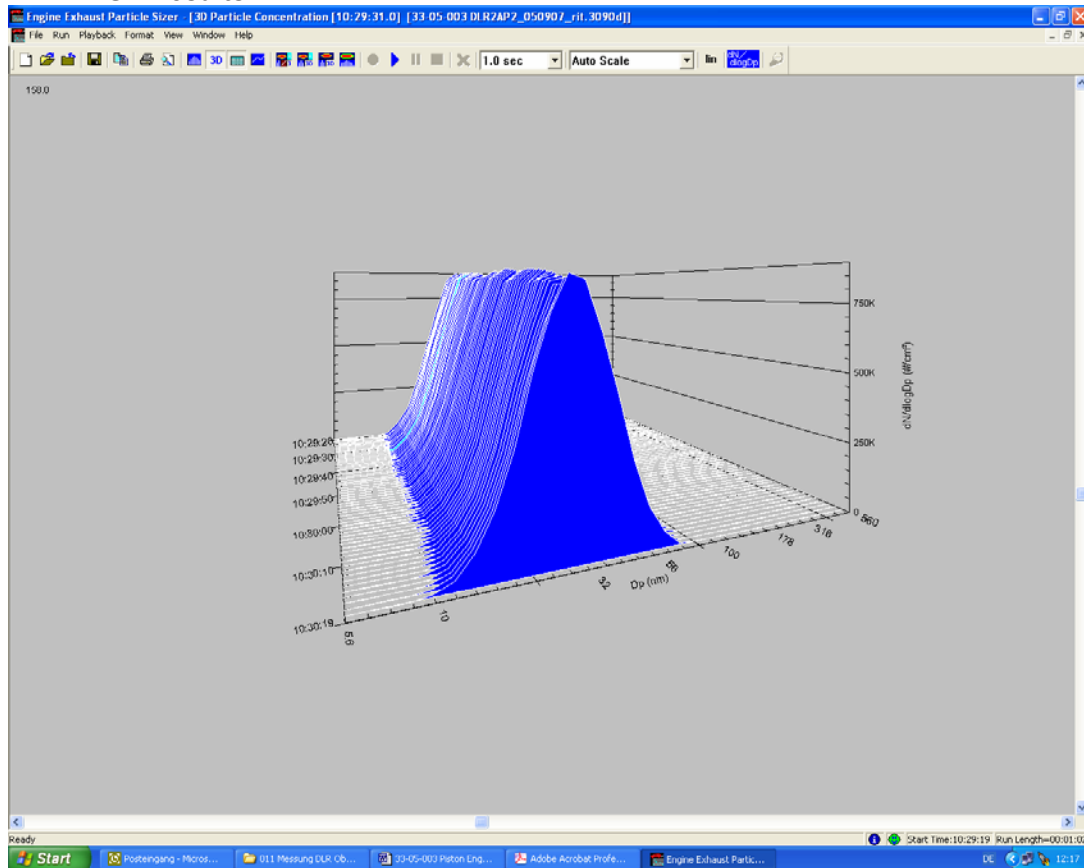

Figure 15: While the power setting is constant, the number-size distributions show a constant shape in successive measurements at a rate of 10 times per second. (Proof for engine emission flow rate stability and combustion and measurement stability.)

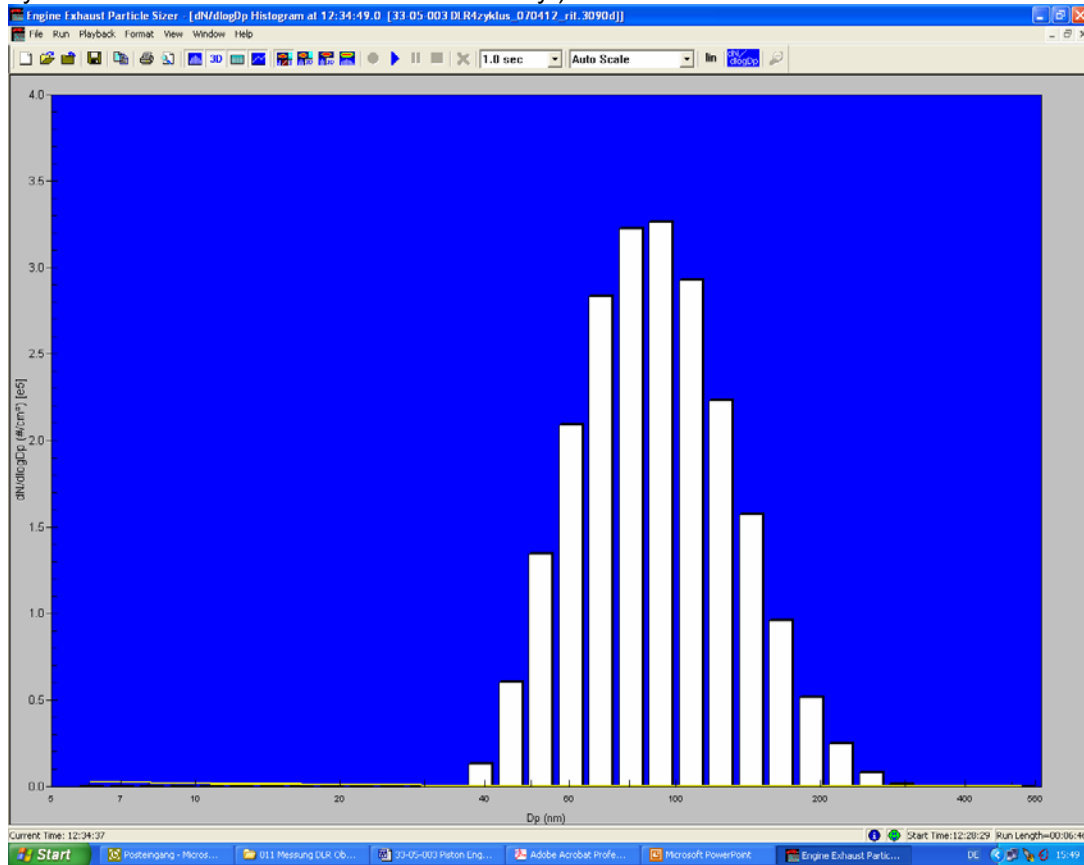

Figure 16: Example of a number-size distribution of non-volatile particles for approach mode of the HB-KEZ engine, measured with EEPS™. With a mean diameter of 100 nm and an overall total concentration of $8 \cdot 10^7$ particles / cm³, the SMPS™ values for approach mode were confirmed.

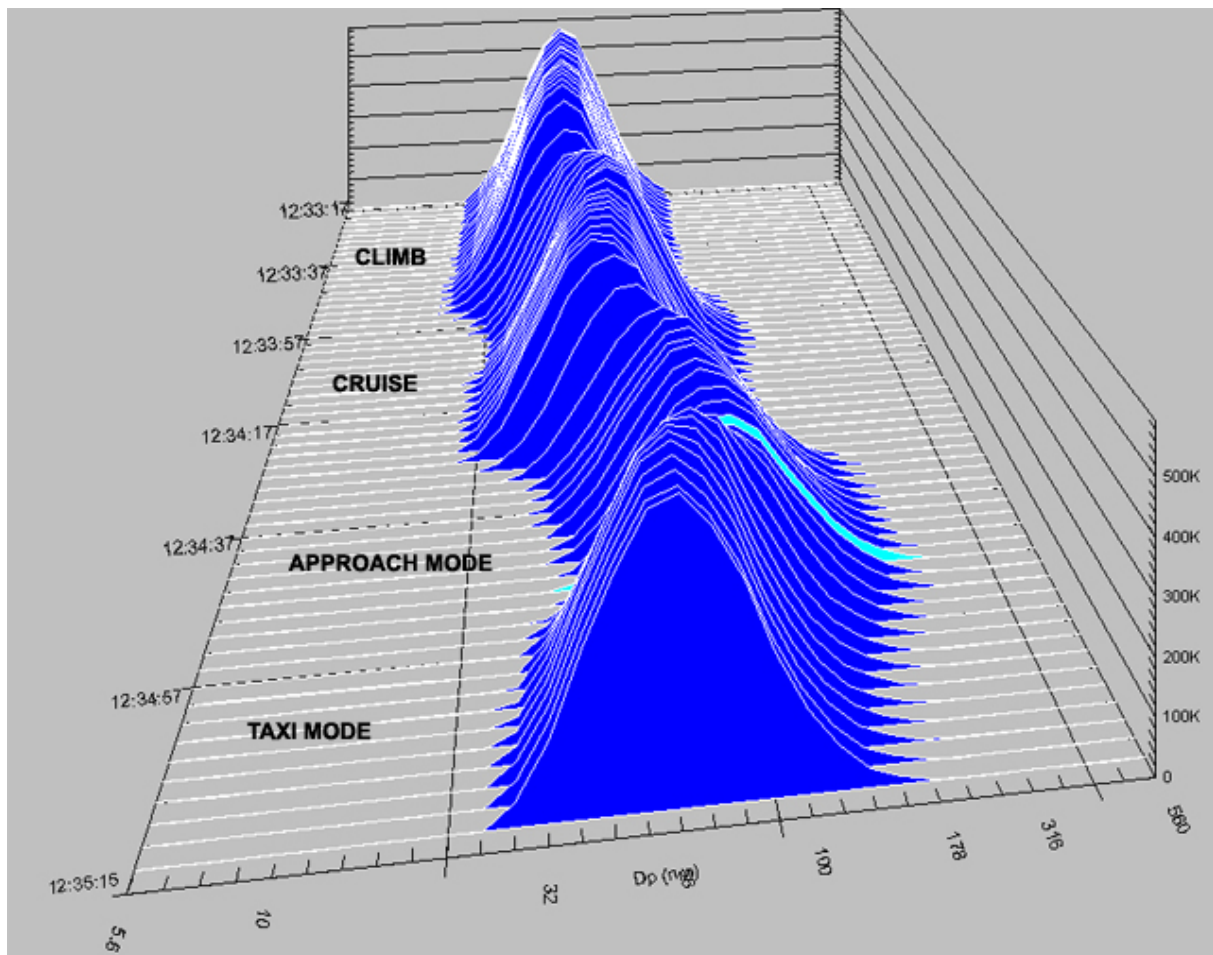

Figure 17: EEPS™ measurement of a power cycle. Each slice represents the mean of 1 second measurement time. The left axis shows the measurement time, the x-axis in front the particle size and the z-axis on the right shows the particle number per cm³, as measured after dilution. The first set of number-size distributions on top of the figure belongs to the climb power setting, followed by cruise power (12.33.57), approach power (12.34.37) and taxi power setting (12.35.00). The approach power number-size distribution shown in figure 16 is taken from this cycle and is marked in light blue.

4.5 First conclusions for EEPS™ measurements

- The system showed robustness with respect to low ambient temperatures and high relative humidity
- The results of the SMPS™ measurements have generally been confirmed for the different modes (see section 2.3, picture 3)
- For the first time, nanoparticle emissions during transient aircraft piston engine power conditions could be observed.
- Engine running time was very short compared to SMPS™ measurements.

5. Research for AVGAS 100LL substitution and emission reduction

Following the conclusions from section 3.9, the Swedish producer of unleaded AVGAS, Hjelmcö Oil, provided FOCA with a variety of different unleaded AVGAS fuels. The main goal was to find a lead free AVGAS that would have a similar high aviation octane rating like 100LL with superior emissions performance and economically feasible production costs. In other words: The research is aimed to find an environmentally beneficial and safe full substitute for AVGAS 100LL. Please note that aviation octane rating is not directly comparable to the research octane number (ROZ) used e.g. for car gasoline. An AVGAS 100 may have a ROZ well above 105. So, an aviation fuel rated at "100" has a significantly higher octane rating than lead free car gasoline.

The composition of the research fuels is known to DLR and FOCA but is part of a confidentiality agreement because this is proprietary data. Therefore, the fuels from Hjelmcö™ are just labeled "A" to "H" in this documentation.

5.1 Test fuels

- Fuel A: Standard unleaded AVGAS 91/96UL, as tested before (section 3).
Fuel B to H: unleaded AVGAS which, in comparison to Fuel A, had one or more components replaced and/or additives.
Fuel I: Standard leaded AVGAS 100LL
Fuel J: Standard MOGAS (lead free car gasoline with 98 ROZ, tested in Rotax engine)

Fuels D, F and G have the highest aviation octane rating of all tested unleaded fuels, with fuel G reaching nearly 100, so being comparable to AVGAS 100LL from that point of view.

5.2 Test location

The test location was St. Stephan (LSTS), a former military Airport in the Swiss Alps. The infrastructure was generously provided by the private company "prospective concepts".



Picture 11: Test location St. Stephan, Swiss Alps

5.3 Used aircraft

- | | | | |
|--------|---|--------|---|
| HB-EYS | Type: Robin DR400
Owner: Swiss Confederation
Engine: Lyc O-360 series, 180 HP
Carburetor (Fuels A to I) | SE-KEI | Type: Piper PA28 Warrior II
Owner: Hjelmsco Oil, Sweden
Engine: Lyc O-320 series, 160 HP
Carburetor (Fuels A to I) |
| HB-WAD | Type: Ikarus C-42 (Microlight/Ecolight)
Owner: A. Liechti, Switzerland
Engine: Rotax 912S, 100HP, Carburetor (Fuels A to C and J) | | |

5.4 Measurement Systems

For gaseous emissions, the FOCA measurement system as described in Appendix 1 was used. For particle emissions, the EEPS™ measurement system, described in section 4 of this appendix, was used. Simultaneous measurement with both systems was made possible by two separate heated sampling lines. In addition, at lower power settings, exhaust has been pumped through sample cartridges at a controlled flow rate for later HC speciation (Carbonyl measurements). Pumping time usually was 2 minutes. The speciation was obtained by analysis of the sample cartridges with HPLC (High Performance Liquid Chromatography) in the DLR laboratory.



Picture 12: Gaseous emission analyzers in the white car on the left (FOCA), particle analyzers in the blue-green car on the right (DLR).

5.5 Power settings

Engine power for selected power modes (Take-off, Climb, Cruise, Approach and Taxi) was adjusted according to the FOCA methodology for static on-ground tests, as described in Appendix 3, sections 6.2 and 6.3. It must be noted that the airport elevation of 3274 ft AMSL (with the prevailing air density at the time of measurement) reduced the maximum propeller power output of the tested engines to about 88%, compared to sea level standard conditions.



Picture 12: Measurement of SE-KEI engine

5.6 Results

As described in section 3.7, the two tested Lycoming engines have a quite different air/fuel mixture characteristic. The Rotax engine is running less rich at high power than the Lycoming engines. Therefore, if all three engines independently show the same trend, we consider this as a more general effect, not only valid for one particular aircraft piston engine. As far as particle emissions are concerned, we focus on the results for the SE-KEI engine. The reason is given by the fact that the engine of HB-EYS has been running on leaded fuel for its whole life (more than 1600 hours). With a lot of lead deposits in the engine, significant amounts of particles have been detected in the exhaust even with unleaded fuel. The SE-KEI engine has the same basic design as the HB-EYS engine.

5.6.1 Ranking of the fuels in terms of emission factors for gaseous emissions

The resulting fuel consumption for a certain power setting in terms of fuel mass did not differ significantly between the tested fuels. This means that measured differences in emission factors directly translate in different emission levels.

The figures 18, 19, 21 and 22 show the **CO and HC emissions ranking** of the tested fuels for full throttle and climb out mode of SE-KEI and HB-EYS. Two groups of fuel can be distinguished: A, E, I, H and C, D, B, G, F. The second group shows a significant drop in CO and HC emissions. This effect is shown with both, the SE-KEI and the HB-EYS engine. For the lower CO and HC emissions group of fuel, one of the original components of the fuel A had been replaced by another.

The figures 20 and 23 show the CO and HC emissions ranking between fuels A, B, C and J, as tested with HB-WAD and the Rotax engine. The lowest emissions have been measured for fuel B and C, confirming the result and corresponding to fuel group two above. Fuel J (MOGAS) showed the lowest total HC emissions of the four fuels, but significantly the highest carbonyl emissions, which is shown in tables 2 to 4.

For the **HC speciation (Carbonyl measurements)**, the following carbonyls have been detected:

Formaldehyde	CH_2O
Acetaldehyde	CH_3CHO
Propargylaldehyde	CHCCHO
Acetone	CH_3OCH_3
Propionaldehyde	$\text{CH}_3\text{CH}_2\text{CHO}$
Crotonaldehyde	$\text{CH}_3\text{CHCHCHO}$
i-Butanale	$\text{i-C}_3\text{H}_7\text{CHO}$
Benzaldehyde	$\text{C}_6\text{H}_5\text{CHO}$
Methylglyoxal	CH_3COCHO
o-Toluene – aldehyde	$\text{CH}_3\text{C}_6\text{H}_4\text{CHO}$
m-Toluene – aldehyde	$\text{CH}_3\text{C}_6\text{H}_4\text{CHO}$
p-Toluene – aldehyde	$\text{CH}_3\text{C}_6\text{H}_4\text{CHO}$

The **ranking for the total carbonyl emissions** has been analyzed for different power settings (see examples in tables 2 to 4). A representative ranking is given below. It is given with falling total carbonyl emissions from left to right:

- SE-KEI (no carbonyl measurement for fuel B)
F, G, D, C (first group) and H, A, E, I (second group)
- HB-EYS
B, D, C, F, G (first group) and E, H, A, I (second group)
- HB-WAD
J (MOGAS), B, C (first group) and A (second group)

Interestingly, the fuels with the lowest CO and lowest total HC emissions produce the highest total carbonyl emissions. In contrast, the (leaded) AVGAS 100LL produces the lowest total carbonyl emissions.

Relative Comparison of CO emission factors for different fuels (SE-KEI, St. Stephan, Switzerland, May 2006)

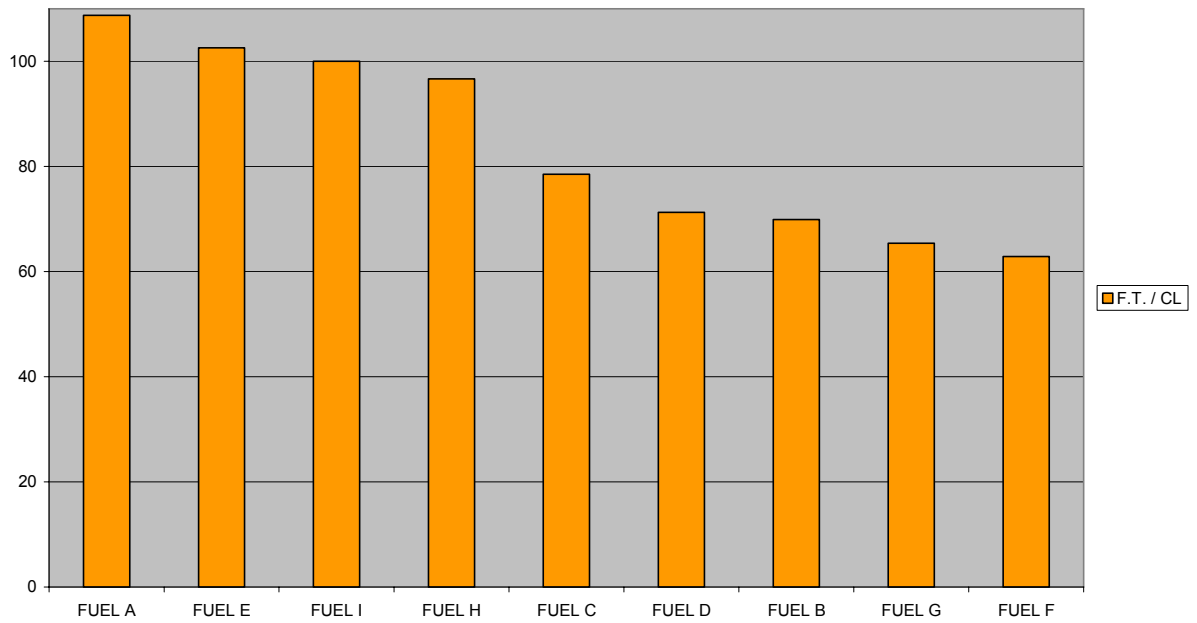

Figure 18: Ranking of the CO emission factors for the tested fuels (SE-KEI engine in climb out mode/full throttle). AVGAS 100LL (Fuel I) is set to 100%.

Relative Comparison of CO emission factors for different fuels (HBEYS, St. Stephan, Switzerland, May 2006)

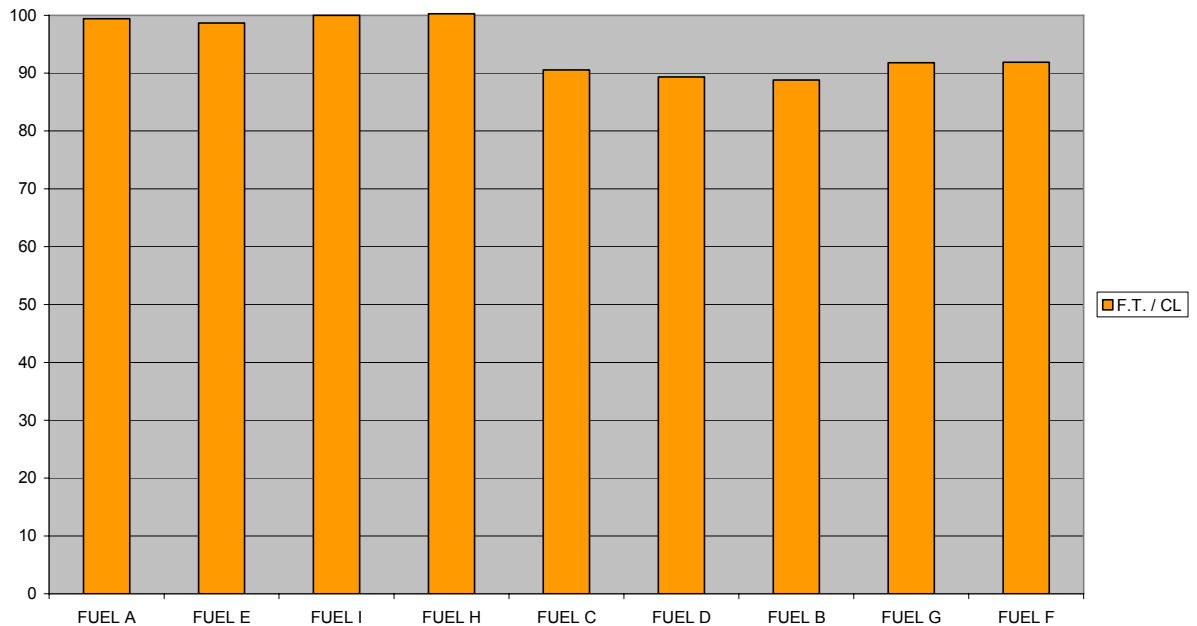

Figure 19: Ranking of the CO emission factors for the tested fuels (HB-EYS engine in climb out mode/full throttle). AVGAS 100LL (Fuel I) is set to 100%.

Relative Comparison of CO emission factors for different fuels (HB-WAD, St. Stephan, Switzerland, June 2006)

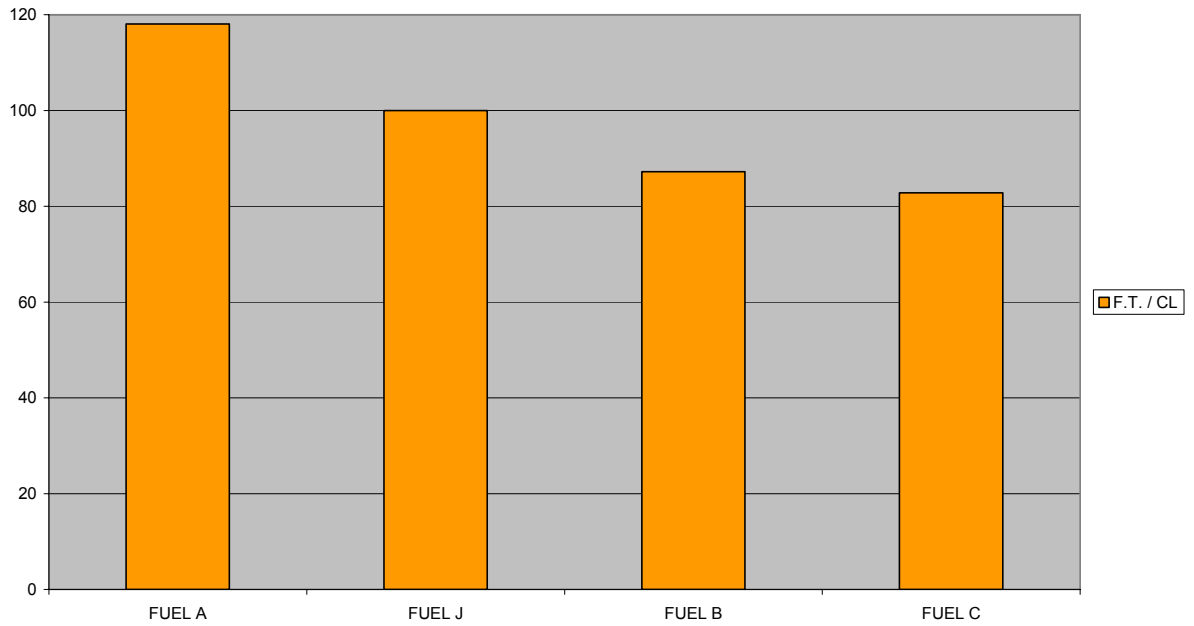

Figure 20: Ranking of the CO emission factors for the tested fuels A, B, C and J with the ROTAX engine at climb out/full throttle setting. MOGAS (car gasoline, fuel J) is set to 100%.

Relative Comparison of HC emission factors for different fuels (SE-KEI, St. Stephan, Switzerland, May 2006)

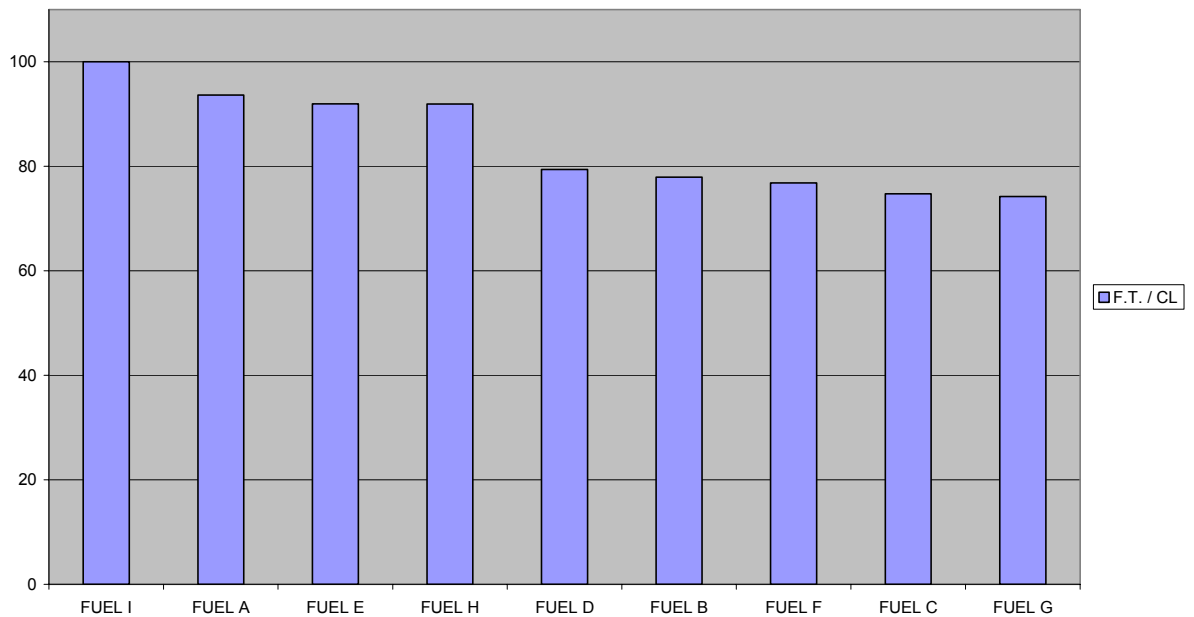

Figure 21: Ranking of the HC emission factors for the tested fuels (SE-KEI engine in climb out mode/full throttle). AVGAS 100LL (Fuel I) is set to 100%.

Relative Comparison of HC emission factors for different fuels (HBEYS, St. Stephan, Switzerland, May 2006)

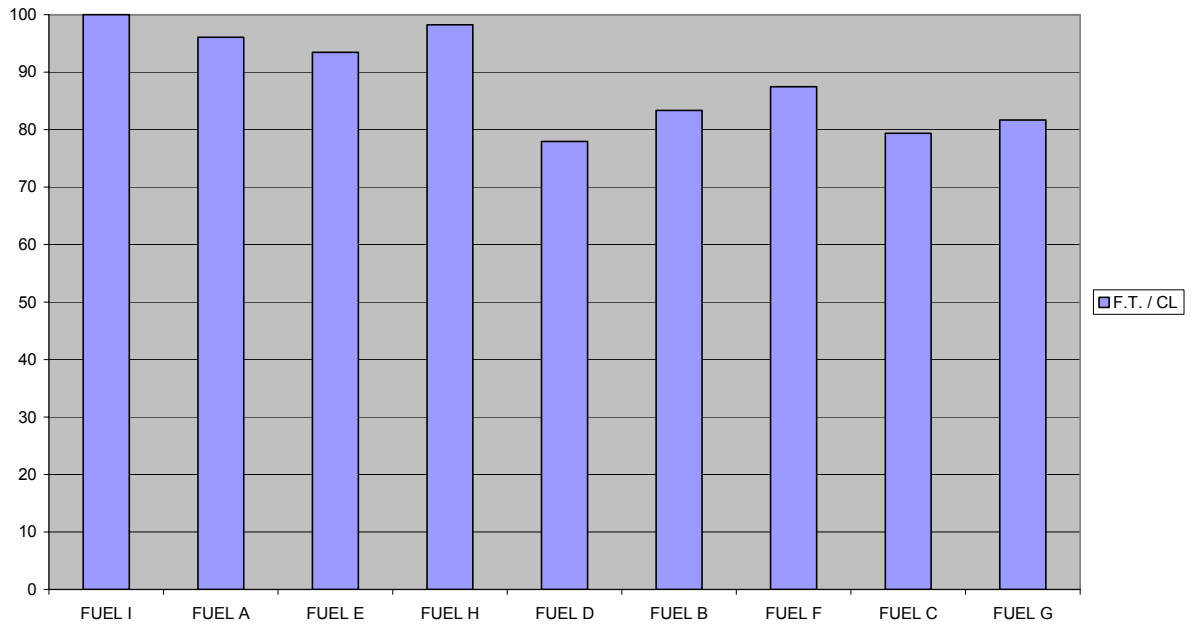

Figure 22: Ranking of the HC emission factors for the tested fuels (HB-EYS engine in climb out mode/full throttle). AVGAS 100LL (Fuel I) is set to 100%.

Relative Comparison of HC emission factors for different fuels (HBWAD, St. Stephan, Switzerland, June 2006)

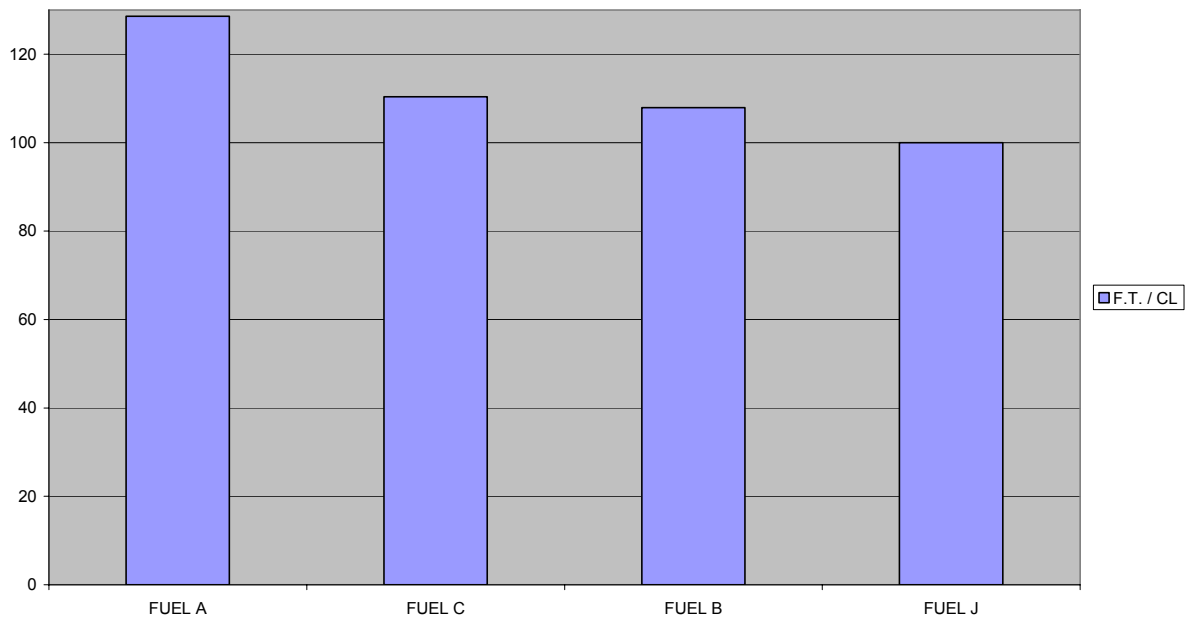

Figure 23: Ranking of the HC emission factors for the tested fuels A, B, C and J with the ROTAX engine at climb out/full throttle setting. MOGAS (car gasoline, fuel J) is set to 100%.

Table 2: Carbonyl emission factors for fuel A, B, C and J (MOGAS). Results for approach mode (HBWAD).[DLR C. Wahl/M. Kapernaum]

Approach mode Carbonyls	Fuel J	Fuel C	Fuel B	Fuel A
	mg/kg Fuel	mg/kg Fuel	mg/kg Fuel	mg/kg Fuel
Formaldehyde	338.25	269.39	290.64	282.20
Acetaldehyde	44.95	97.56	83.22	49.41
Propargylaldehyde	4.55	4.52	5.43	2.20
Acrolein	34.33	34.83	32.66	22.67
Propanaldehyde	2.61	0.79	0.81	3.56
i-Butanaldehyde	24.46	13.04	12.21	15.36
Benzaldehyde	79.70	7.95	8.26	72.43
Methacrolein	69.24	145.73	101.76	69.64
o-Toluolaldehyde	19.709	0	0	2.48
p-Toluolaldehyde	43.42	0	0	1.37
m-Toluolaldehyde	0	0	0	2.73
2,5-Dimethylbenzaldehyde	13.586	0	0	0
3,4-Dimethylbenzaldehyde	23.059	0	0	0
2,4-Dimethylbenzaldehyde	24.297	0	0	0
Sum	722.16	573.82	534.98	524.05

Table 3: Carbonyl emission factors for fuel A, B, C and J (MOGAS). Results for cruise mode (HBWAD). [DLR C. Wahl/ M. Kapernaum]

Cruise 65% power Carbonyls	Fuel J	Fuel C	Fuel B	Fuel A
	mg/kg Fuel	mg/kg Fuel	mg/kg Fuel	mg/kg Fuel
Formaldehyde	306.36	261.48	288.23	269.60
Acetaldehyde	55.62	103.62	96.84	36.69
Propargylaldehyde	3.65	2.50	2.75	1.29
Acrolein	23.42	23.34	22.38	16.15
Propanaldehyde	3.89	0.94	1.44	2.55
i-Butanaldehyde	28.53	9.56	9.38	0
Benzaldehyde	89.38	5.34	9.60	66.84
Methacrolein	82.01	92.48	88.73	60.57
o-Toluolaldehyde	21.90	0	0	1.45
p-Toluolaldehyde	17.97	0	0	1.60
m-Toluolaldehyde	34.57	0	0	2.79
2,5-Dimethylbenzaldehyde	15.97	0	0	0
3,4-Dimethylbenzaldehyde	26.55	0	0	0
2,4-Dimethylbenzaldehyde	28.34	0	0	0
Sum	738.14	499.25	519.35	459.51

Table 4: Carbonyl emission factors for fuel A, B, C and J (MOGAS). Results for climb mode/full throttle (HBWAD) [DLR C. Wahl/ M. Kapernaum]

Climb/Full throttle Carbonyls	Fuel J	Fuel C	Fuel B	Fuel A
	mg/kg Fuel	mg/kg Fuel	mg/kg Fuel	mg/kg Fuel
Formaldehyde	389.16	344.79	386.22	230.63
Acetaldehyde	71.34	220.80	234.52	39.41
Propargylaldehyde	4.02	2.09	2.92	1.37
Acrolein	55.55	74.15	69.53	20.55
Propanaldehyde	7.49	3.26	2.46	0.71
i-Butanaldehyde	15.43	9.88	10.60	30.76
Benzaldehyde	130.85	15.99	25.70	62.24
Methacrolein	142.81	154.95	154.60	0
o-Toluolaldehyde	29.67	0	0	2.67
p-Toluolaldehyde	71.01	0	0	1.74
m-Toluolaldehyde	0.00	0	0	2.74
2,5-Dimethylbenzaldehyde	22.06	0	0	0
3,4-Dimethylbenzaldehyde	37.57	0	0	0
2,4-Dimethylbenzaldehyde	41.44	0	0	0
Sum	1018.39	825.91	886.56	392.81

The figures 24, 25 and 26 show the **NOx emissions ranking** of the tested fuels. The two groups of fuels mentioned for the CO and HC emissions ranking are confirmed with all engines, but this time the ranking of the fuels is the other way round, with MOGAS and the C, D, B, G, F fuels producing the highest NOx emissions.

Relative Comparison of NOx emission factors for different fuels (SE-KEI, St. Stephan, Switzerland, May 2006)

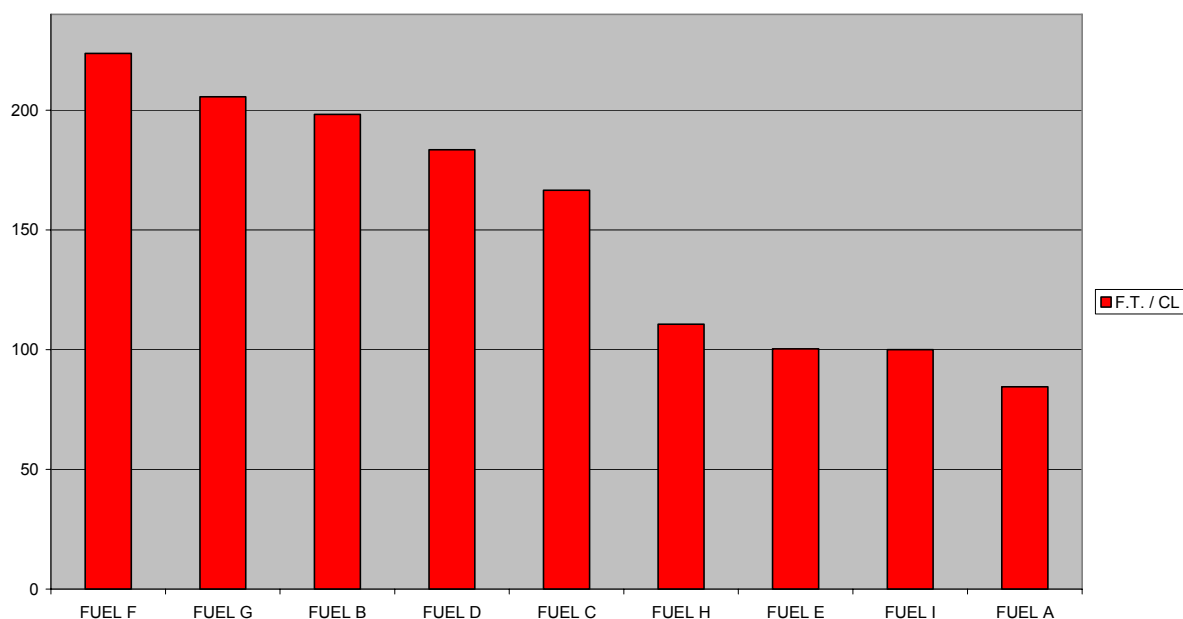

Figure 24: Ranking of the NOx emission factors for the tested fuels (SE-KEI engine in climb out mode/full throttle). AVGAS 100LL (Fuel I) is set to 100%.

Relative Comparison of NOx emission factors for different fuels (HBEYS, St. Stephan, Switzerland, May 2006)

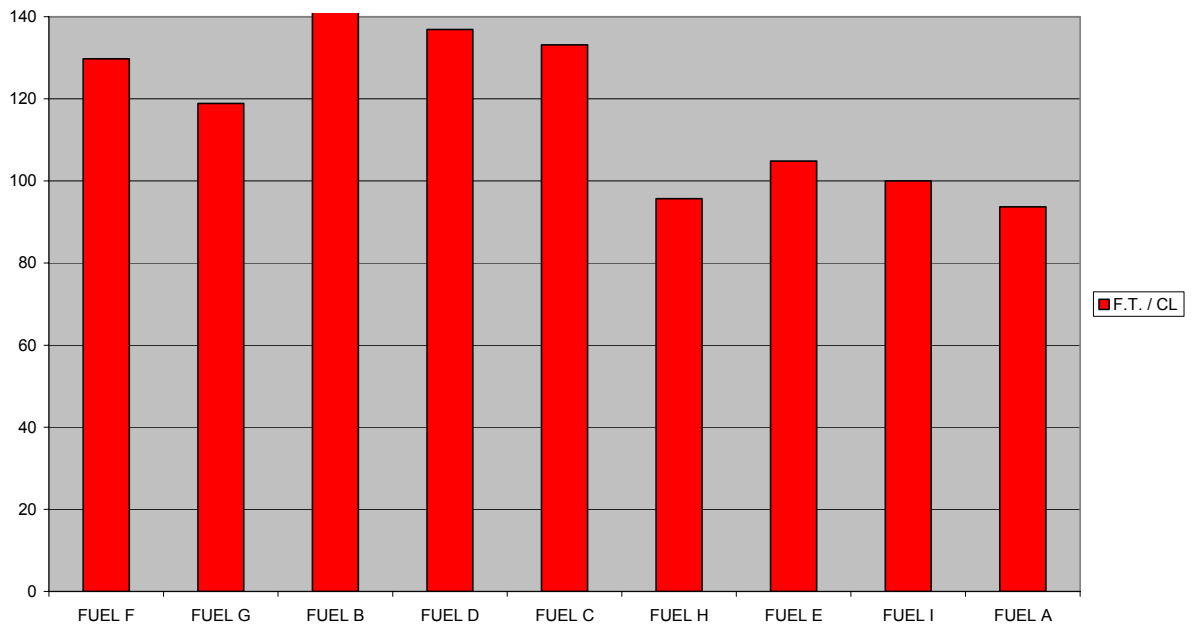

Figure 25: Ranking of the NOx emission factors for the tested fuels (HB-EYS engine in climb out mode/full throttle). AVGAS 100LL (Fuel I) is set to 100%.

Relative Comparison of NOx emission factors for different fuels (HB-WAD, St. Stephan, Switzerland, June 2006)

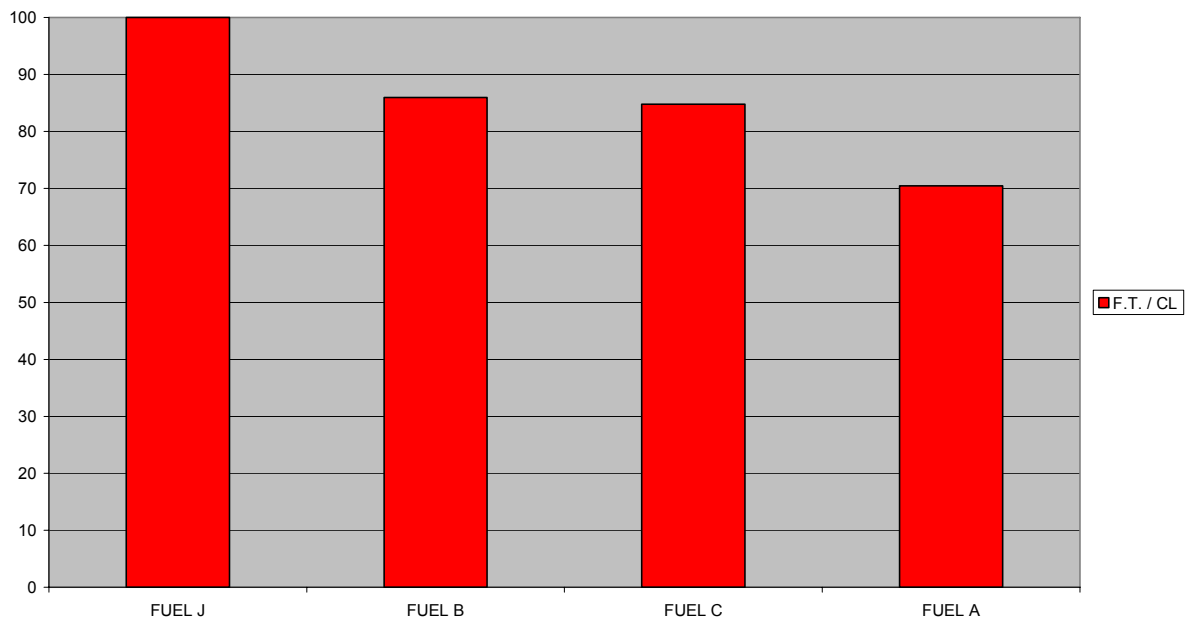

Figure 26: Ranking of the NOx emission factors for the tested fuels A, B, C and J with the ROTAX engine at climb out/full throttle setting. MOGAS (car gasoline, fuel J) is set to 100%.

5.6.2 Ranking of the fuels in terms of particle emissions

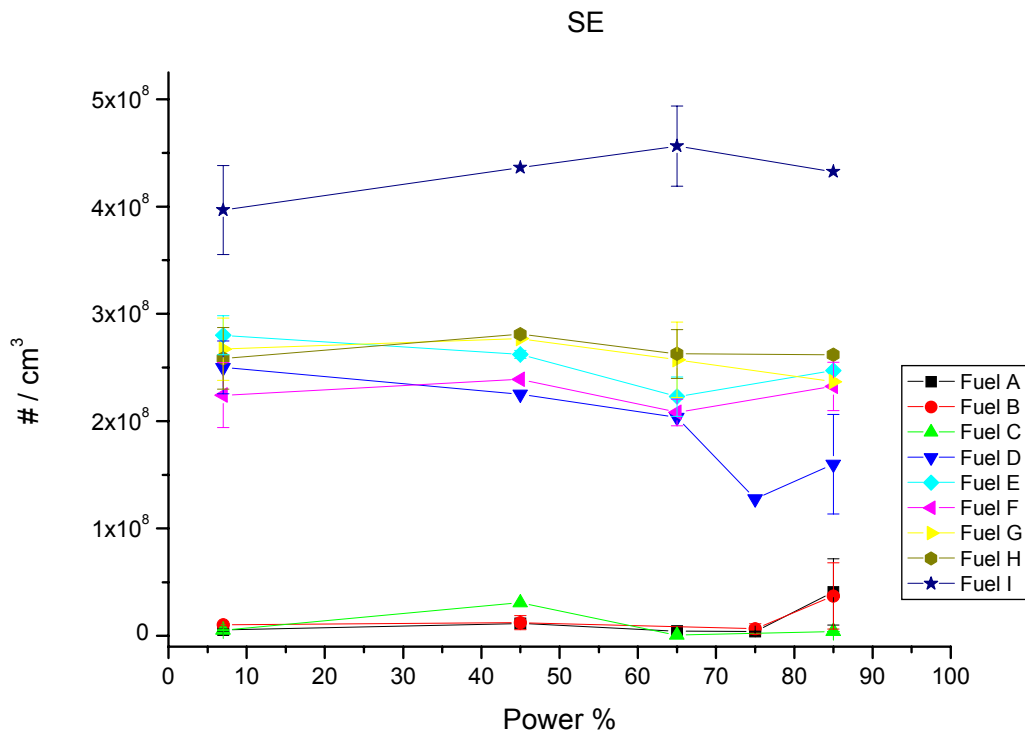

Figure 24: Particle number concentration for the different test fuels (SE-KEI engine) in function of propeller power. [DLR, C. Wahl, M. Kapernaum]

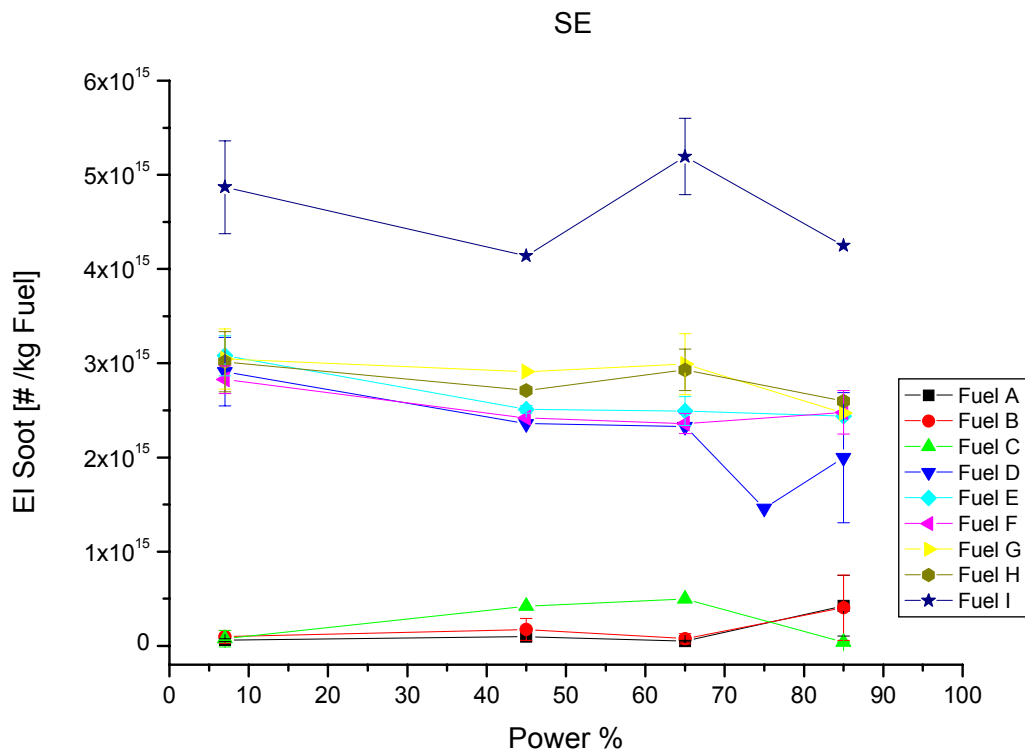

Figure 25: Emission factor for the number of soot particles per kg fuel for the different test fuels (SE-KEI engine) in function of propeller power. [DLR, C. Wahl, M. Kapernaum]

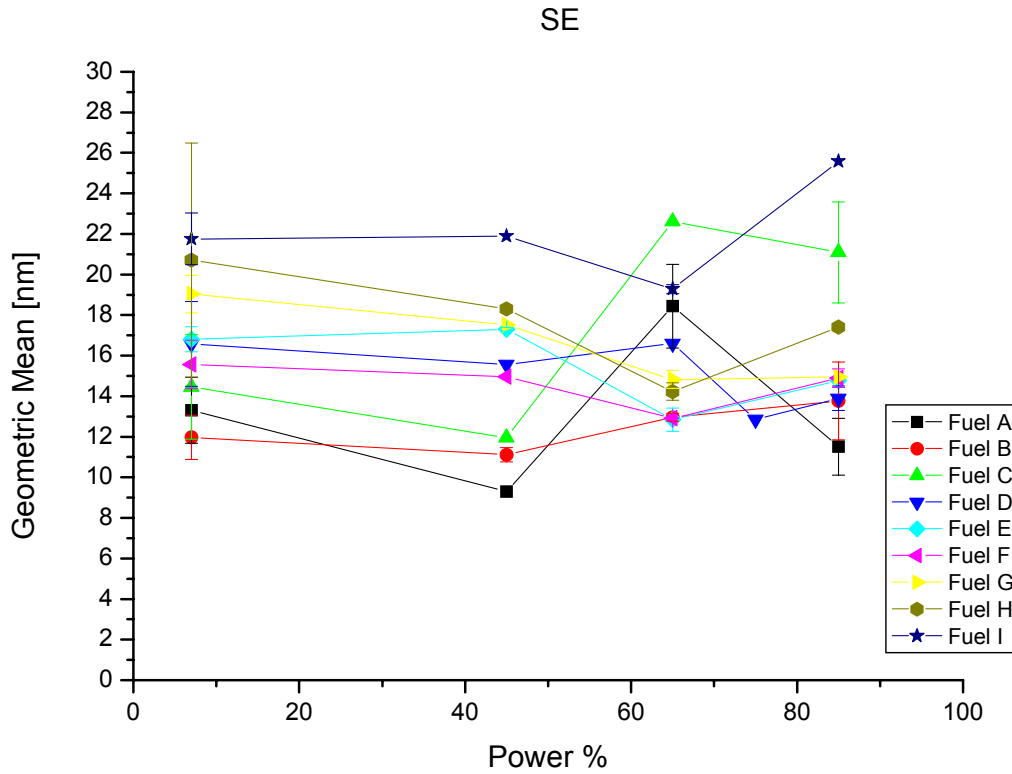

Figure 26: Geometric mean diameter of emitted nanoparticles for the different test fuels (SE-KEI engine) in function of propeller power. [DLR, C. Wahl, M. Kapernaum]

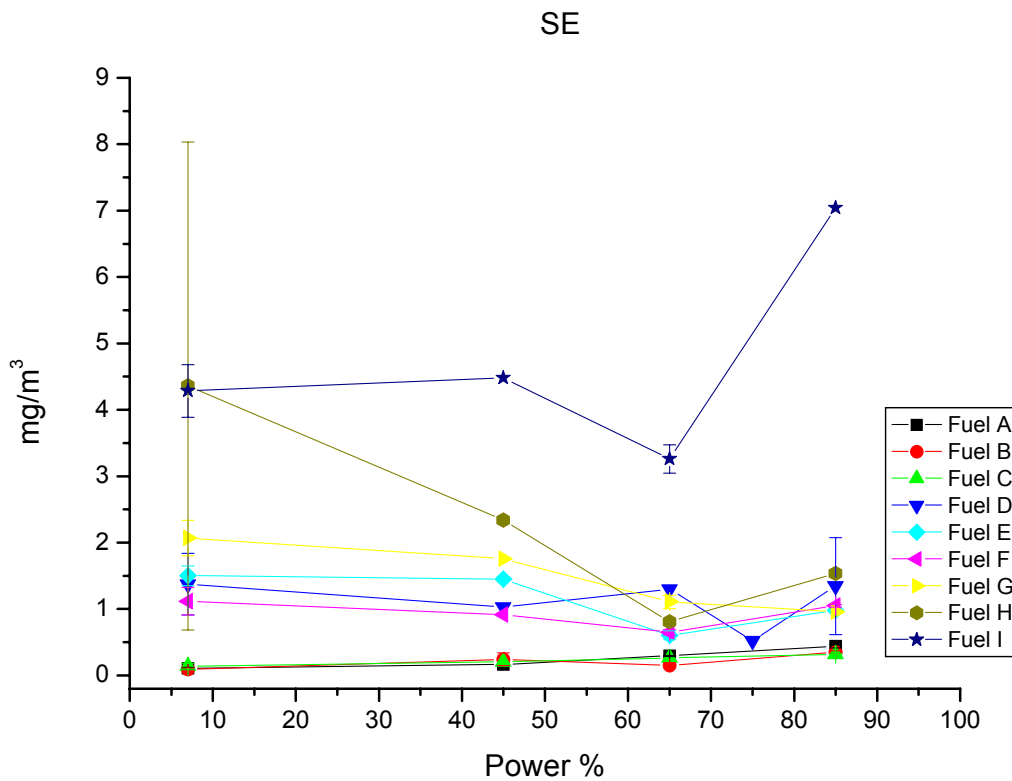

Figure 27: Emitted particle mass per exhaust volume for the different test fuels (SE-KEI engine) in function of propeller power. [DLR, C. Wahl, M. Kapernaum]

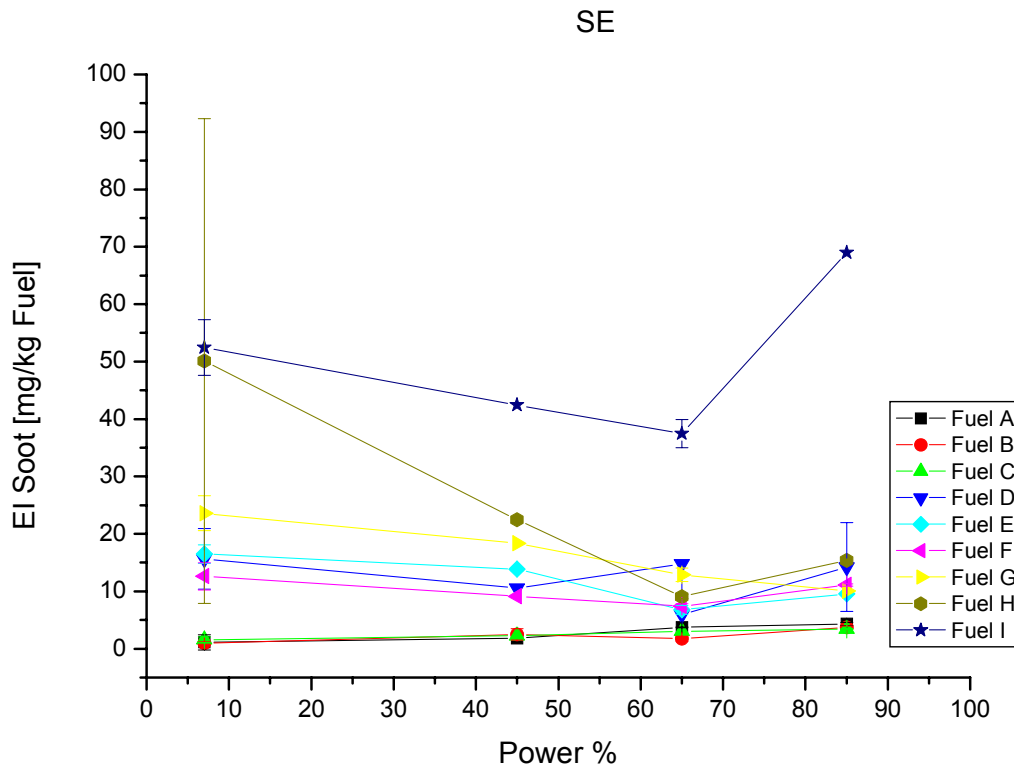

Figure 28: Emission factor for emitted particle mass for the different test fuels (SE-KEI engine) in function of propeller power. [DLR, C. Wahl, M. Kapernaum]

5.7 Discussion:

For gaseous emissions, an effect of different additives can not be clearly identified. If differences existed, they would be below the measurement accuracy of the FOCA analyzer system. However, differences occurring from different composition of the fuels are clearly visible:

One way to maintain an acceptable level of octane number without using lead-tetra-ethyl is by adding oxygen containing substances to the fuel. The effect of this is most pronounced with the tested lead free car gasoline (MOGAS, fuel J). The additional oxygen provided by the fuel reduces CO and total HC emissions and increases NO_x emissions. In fact, the tested MOGAS contained large amounts of MTBE². This substance might be the cause for the significantly high carbonyl emissions of the tested MOGAS. In addition to that, a substance like MTBE can pose a certain risk for the contamination of drinking water.

In order to rank the tested fuels with respect to particle emissions, the fuels can be separated into three groups:

The fuels A, B and C have the lowest particle number concentrations and the smallest particle diameter, leading to the lowest particle mass emissions. (group 1)

Fuel I (AVGAS 100LL) has the highest particle number concentrations and the highest particle diameters, leading to the highest particle mass emissions. (group 3)

The fuels D, E, F, G, and H (group 2) are situated between the group 1 and 3 fuels. The higher particle emissions of this group of fuels compared to group 1 can be explained by a fuel additive, which is missing in the group 1 fuels. However, particle number concentrations and particle mass emissions are still lower than with AVGAS 100LL (group 3).

² MOGAS sold in Switzerland and analyzed in 2006 contained quite large quantities of MTBE (Methyl tert-butyl ether).

As we have seen, there is no lead free highest octane fuel producing the lowest possible emissions (CO, total HC, Carbonyls, NOx and particles) among the tested fuels. A compromise seems to be needed, weighing the different trade-offs.

5.8 First conclusions

As far as particle emissions are concerned, the standard unleaded AVGAS 91/96UL (Fuel A) has again proven its superior environmental performance.

If not highest octane number is required, an AVGAS like fuel C seems to be a valuable compromise.

Fuel G, which would have the potential to fully replace AVGAS 100LL from point of view of aviation octane rating, has a better environmental performance than AVGAS 100LL, but worse than e.g. fuel C.



Picture 13: The measurement team. From left to right: C. Wahl, M. Kapernaum (both DLR), L. Hjelmberg (Hjelmco), T. Rindlisbacher, W. Bula (both FOCA)



Picture 14: HB-WAD (with Rotax engine) was generously provided for the fuel tests by A. Liechti, Switzerland. Many thanks also to K. Moser (first to the right, the pilot of HB-WAD), who contributed to the measurements in his spare time.